



FLEXIHEAT UK LTD

www.flexiheatuk.com

01202 822221

Installation, Use and Maintenance Manual for model

SFK 34 RAIN

Condensing water heater
suitable for outdoor installation

CE 0476

SFK 34 RAIN - RAD - ING - Manuale - 2103.1_SKM1_firm.L225B

SUMMARY

INTRODUCTION	4
--------------	---

1. INSTALLER SECTION 7

1.1. INSTALLATION	8
1.1.1. WATER HEATER LOCATION ENVIRONMENTAL REQUIREMENTS	8
1.1.2. REFERENCE LEGISLATION	9
1.1.3. UNPACKING	10
1.1.4. POSITIONING AND MINIMAL TECHNICAL SPACES	11
1.1.5. OVERALL DIMENSIONS	13
1.1.6. HYDRAULIC CONNECTIONS	13
1.1.7. RECIRCULATION MODE PUMP HEAD / FLOW DIAGRAM	14
1.1.8. HYDRAULIC CONNECTION	15
1.1.9. RECIRCULATION MODE	16
1.1.10. D.H.W. PRODUCTION THRU A REMOTE TANK	17
1.1.11. FILLING THE CONDENSATE COLLECTION SIPHON	18
1.1.12. ANTI-FREEZE PROTECTION	19
1.1.13. GAS CONNECTION	20
1.1.14. ELECTRICAL CONNECTION	20
1.1.15. POWER SUPPLY	21
1.1.16. OPTIONAL ELECTRICAL CONNECTIONS	22
1.1.17. FUME EXHAUST FITTINGS	24
1.1.18. INSTALLATION MODES	25
1.1.19. TYPES OF FUME EXHAUST SYSTEMS	27

2. SUPPORT CENTER SECTION 31

2.1. FIRST START-UP	32
2.1.1. PRELIMINARY OPERATIONS FOR FIRST START-UP	32
2.1.2. WATER HEATER COMMISSIONING	33
2.1.3. CO2 VALUE CHECK AND CALIBRATION	34
2.1.4. ACCESSING AND PROGRAMMING THE PARAMETERS	35
2.1.5. DIGITECH CS PARAMETERS TABLE	37
2.2. MAINTENANCE	43
2.2.6. GENERAL MAINTENANCE WARNINGS	43
2.2.7. TECHNICAL DATA	44
2.2.8. TECHNICAL ASSEMBLY	46
2.2.9. HYDRAULIC BOARD	47
2.2.10. WIRING DIAGRAM	49
2.2.11. ACCESSING THE WATER HEATER	50
2.2.12. ACCESSING THE ELECTRONIC BOARD	51

2.2.13. EMPTYING THE DOMESTIC SYSTEM.....	52
2.2.14. FAULT SIGNALLING CODES.....	53
2.2.15. ACTIVE FUNCTIONS SIGNALLING CODES.....	58
2.2.16. GAS TYPE TRANSFORMATION.....	59

3. USER SECTION 61

3.1. USE.....	62
3.1.1. GENERAL USE WARNINGS.....	62
3.1.2. CONTROL PANEL.....	63
3.1.3. DISPLAY ICONS.....	64
3.1.4. INFO MENU DISPLAY DATA.....	65
3.1.5. START-UP.....	66
3.1.6. OPERATING MODE.....	66
3.1.7. INFORMATIONAL NOTE ON ANTI-FREEZE FUNCTION.....	66
3.1.8. FAULT SIGNALLING CODES.....	67
3.1.9. ACTIVE FUNCTIONS SIGNALLING CODES.....	69
3.1.10. FAST H2O FUNCTION.....	69
3.1.11. MAINTENANCE.....	70
3.1.12. COVER CLEANING.....	70
3.1.13. DISPOSAL.....	70

INTRODUCTION

WARNING

Before starting any operation it is mandatory to read this instruction manual, in relation to the activities to be carried out as described in each relevant section. Proper operation and optimal performance of the water heater are ensured by strict compliance with all the instructions given in this manual.

The installation, use and maintenance manual is an integral and essential part of the product and must be delivered to the user.

MANUAL USERS

The manual users are all those who install, use and maintain the water heater.

The water heater must be used and accessed only by qualified operators that fully read and understood the use and maintenance manual, paying particular attention to the warnings.

READING AND SYMBOLS OF THE MANUAL

To ease the understanding of this manual, recurrent symbols where used, in particular:

- › On the outer margin of the page is placed a thumb index indicating the type of user to which the instructions in that section address.
- › The titles are differentiated by thickness and size in accordance with their hierarchy.
- › The images contain important parts described in the text, marked with numbers or letters.
- › (See chap. "chapter name"): this entry indicates another section in the Manual that you should refer to.

- › Device: this term is used referring to the water heater.



DANGER

It identifies an information related to a general danger that if not complied with, may cause serious personal damage or even death.



ATTENTION

It identifies an information that if not complied with may cause small or medium level lesions to the person or serious deterioration to the water heater.



WARNING

It identifies a precaution information that must be observed in order to avoid damaging the machine or parts of it.

MANUAL STORAGE

The manual must be carefully stored and replaced in case of deterioration and/or low legibility.

If you misplace the use and maintenance manual, you can request it from the Service Centre giving the serial number and model of the boiler indicated on the data plate placed on the right side of its casing.

MANUFACTURER WARRANTY AND RESPONSIBILITY

equipped with all accessories necessary to render it a veritable independent heating unit. All water heaters are tested and delivered with a quality certificate signed by the tester.

The technical and functional features of the device are ensured by its use in compliance:

1. with the use and maintenance instructions contained in the manuals accompanying the product, the content of which the customer certifies that he is aware;
2. with the conditions and purposes to which devices of the same type are intended.

For more information on the warranty validity, its duration, the obligations and the exemptions, please consult the First start-up certificate attached to this manual.

The manufacturer reserves:

- › the right to modify the tools and relative technical documentation without any obligation to third parties; neither will the company be held responsible for any inaccuracies in this handbook deriving from printing or translation errors;
- › the material and intellectual ownership of this manual and forbids its distribution and duplication, even partial, without prior written authorization.

PRODUCT CONFORMITY

The materials used such as copper, brass, stainless steel create a homogeneous, compact and functional assembly, easy to install and manage. In its simplicity, the water heater is

1. INSTALLER SECTION

The installation operations described in this section, must be performed only by qualified personnel, having the appropriate technical training in the field for the installation and maintenance of components of civil and industrial domestic hot water production and heating plants.

1.1. INSTALLATION



ATTENTION

This water heater may be used only for the purpose for which it has been designed: heat water to a temperature below boiling point at atmospheric pressure. Any other use is considered wrong and dangerous. The manufacturer is excluded from any contractual or extra-contractual responsibility for damages caused to people, animals or property due to errors during installation.



ATTENTION

This water heater must be installed only by qualified personnel, having the appropriate technical training in the field for the installation and maintenance of components of civil and industrial domestic hot water production and heating plants.



ATTENTION

After having removed the packing, make sure the device is intact. In case of doubt, do not use the device and contact the supplier.

BEFORE INSTALLING THE WATER HEATER, THE INSTALLER MUST MAKE SURE THAT THE FOLLOWING CONDITIONS ARE MET:

- › The device is connected to a heating system and a water supply network appropriate for its power and performance.
- › The location must be properly vented through an air vent.
- › The air vent must be placed at floor level to prevent it from being obstructed, protected by a grid that does not hamper the useful passage section.
- › The device is suitable for use with the type of gas available by checking the water heater data plate (placed on the inner side of the front casing).

- › Make sure that the pipes and joints are perfectly sealed, without any gas leaks.
- › Make sure that the grounding system works properly.
- › Make sure that the electrical system is suitable for the maximum power absorbed by the device, value indicated on the data plate.

1.1.1. WATER HEATER LOCATION ENVIRONMENTAL REQUIREMENTS

The device installation location should be vented due to the presence of threaded joints on the gas supply line. The location should be therefore provided with vents as to ensure air exchange, with output grid in the natural accumulation area of potential gas losses.



WARNING

DO NOT install the water heater in a technical compartment near a swimming pool or a laundry, to avoid that the combustion air is exposed to chlorine, ammonia or alkaline agents that may worsen the corrosion phenomenon of the heat exchanger. Failure to observe this caution will void the warranty of the heat exchanger.

THIS WATER HEATER HAS BEEN DESIGNED FOR OUTDOOR INSTALLATION IN A PARTIALLY PROTECTED LOCATION (SEE FIG.2 AT CHAPTER 'POSITIONING AND MINIMAL TECHNICAL SPACES').

The ABS material water heater casing is approved for the exposition to atmospheric agents and, in particular, to UV rays.

THIS WATER HEATER IS ABLE TO OPERATE IN A PARTIALLY PROTECTED PLACE, WITHIN THE AMBIENT TEMPERATURES MINIMUM -10 °C AND MAXIMUM 60 °C.



WARNING

IF THE TEMPERATURE, WHERE THE WATER HEATER IS LOCATED, DROPS BELOW -10°C, IT IS RECOMMENDED TO INSTALL AN ELECTRIC ANTI-FREEZE KIT (SEE CHAPTER 'ANTI-FREEZE PROTECTION)



WARNING

THE COMPANY DOES NOT ACCEPT ANY LIABILITY FOR DAMAGE CAUSED BY INSTALLATIONS IN ENVIRONMENTS THAT DO NOT COMPLY WITH THE ABOVE AND NOT ADEQUATELY PROTECTED FROM FROST

1.1.2. REFERENCE LEGISLATION

The installation must be done according to the requirements of current legislation and in compliance with local technical regulations, according to the indications of the good technique.

1. INSTALLATION

1.1.3. UNPACKING



WARNING

Please unpack the water heater just before installing it. The Company is not responsible for the damages caused to the device due to incorrect storage.



WARNING

The packing elements (cardboard box, wooden crate, nails, fasteners, plastic bags, expanded polystyrene, etc.) must be kept out of the reach of children as they may be dangerous. Therefore they should be dismantled suitably differentiating them in accordance with the standards in force.

To unpack the water heater, proceed as follows:

- > Place the packed water heater on the floor (fig. 1-A) and remove the fasteners opening the four flaps of the box outwards.
- > Turn the water heater at 90° holding it with your hand (fig. 1-B).
- > Lift the box (fig. 1-C) and remove the guards (fig. 1-D).

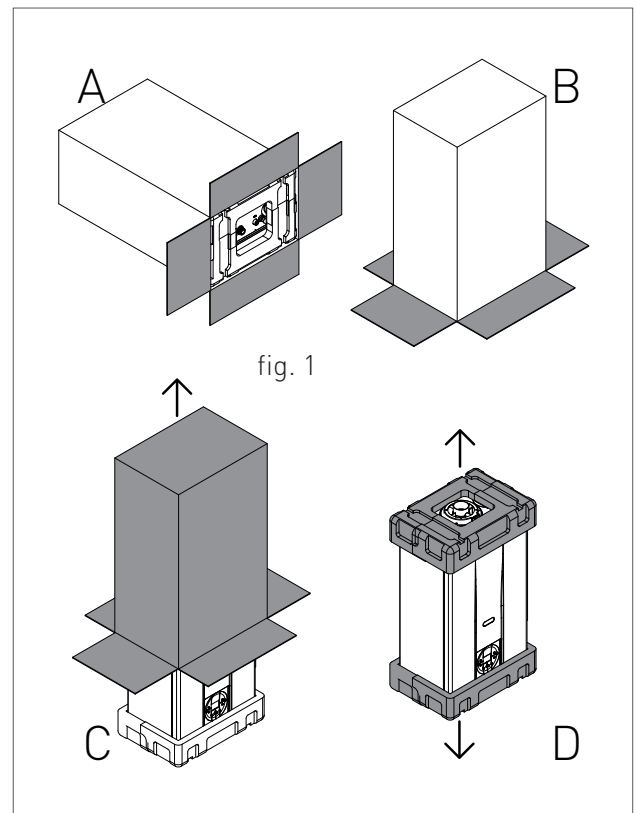

1.1.4. POSITIONING AND MINIMAL TECHNICAL SPACES

The water heater must be installed only on a vertical solid wall, able to sustain its weight.

In order to allow the access inside the water heater for maintenance operations, the minimum technical spaces indicated in figure 1 have to be respected.

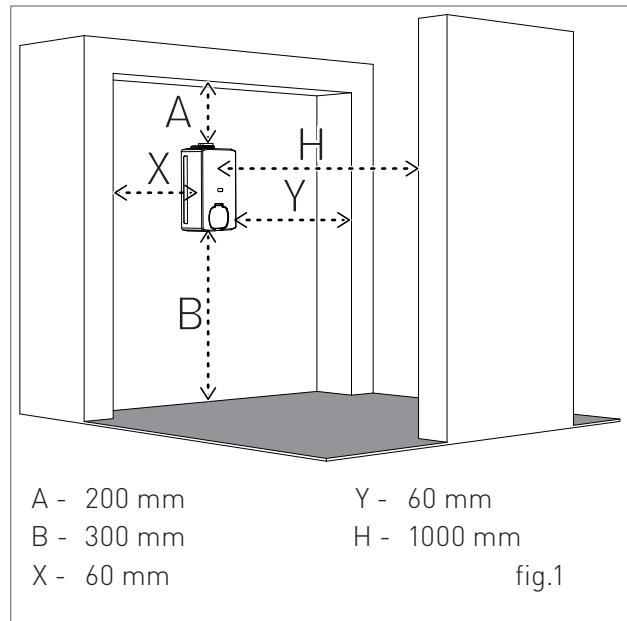

Outdoor installation is allowed in a partially protected place (i.e. shelter, balcony) that respects the minimum measure indicated in figure 2.

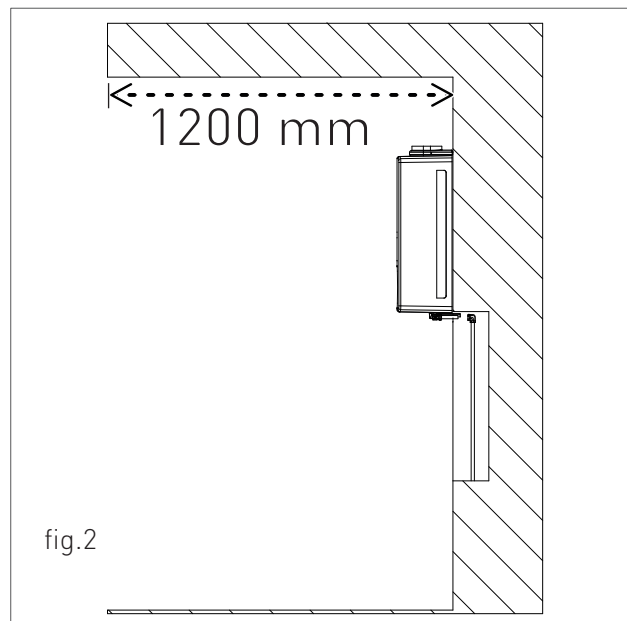

1. INSTALLATION

To facilitate the installation, the water heater is provided with wall template that allows setting in advance the connections to the pipes, offering the possibility to connect the boiler once masonry works are completed.

For water heater positioning, proceed as follows (see fig. 3):

1. Trace a line using a spirit level (min. length 25 cm) on the installation wall;
2. place the top of the template along the traced line respecting the distances of the water connections; then mark the two points to insert the two wall fastening screws, then trace the points for the flue system;
3. remove the template and drill the wall;
4. hang the water heater onto the wall fastening screws or onto the wall hanging bracket and perform the connections.

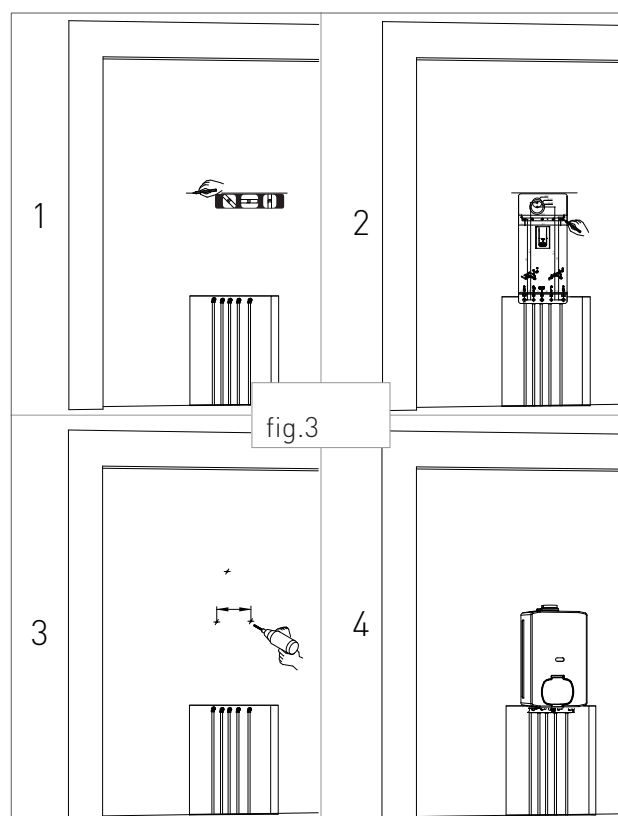

1.1.5. OVERALL DIMENSIONS

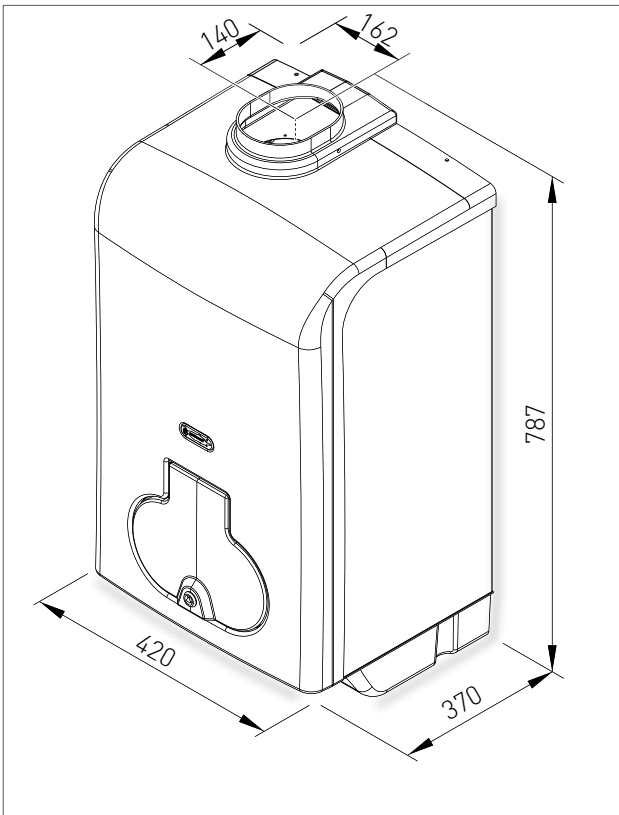

1.1.6. HYDRAULIC CONNECTIONS

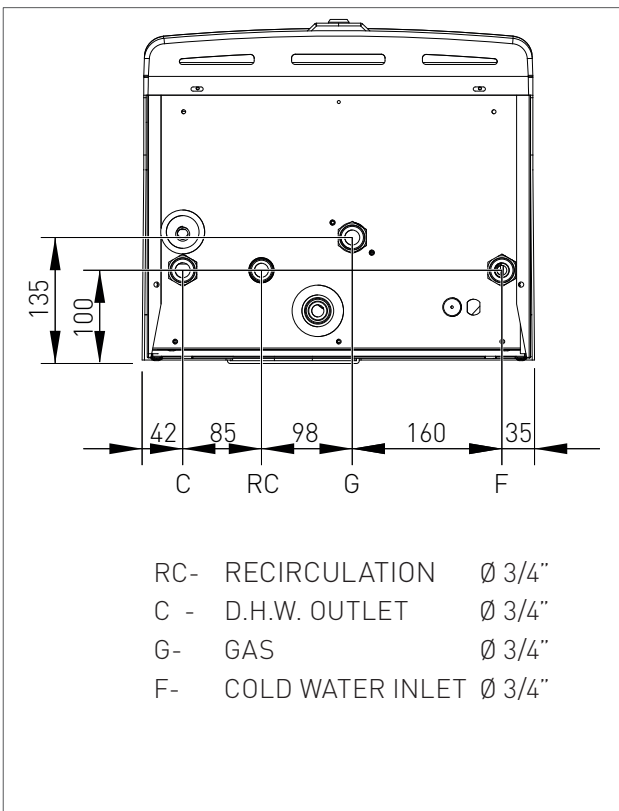

1. INSTALLATION



WARNING

Make sure, using a spirit level, that the water heater is properly inclined being levelled (see fig.1) so as to allow the condensate to drain.

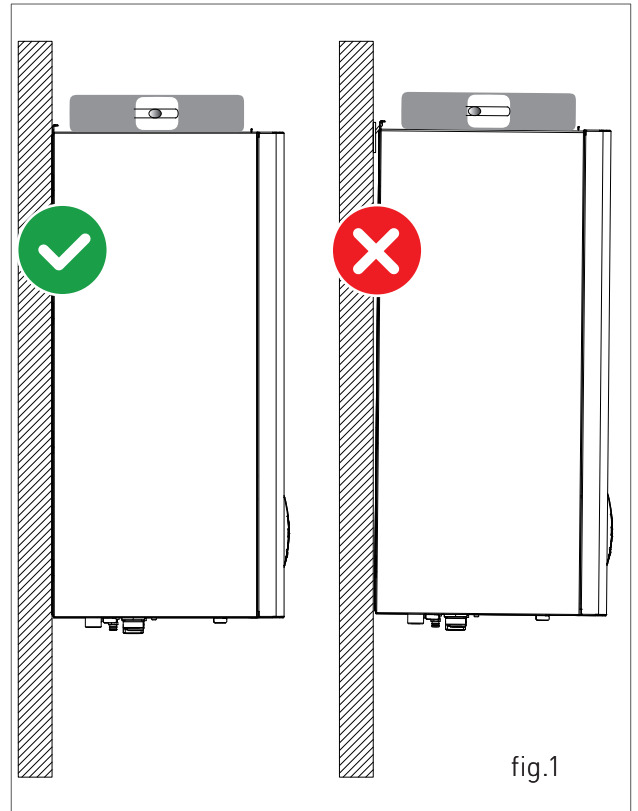
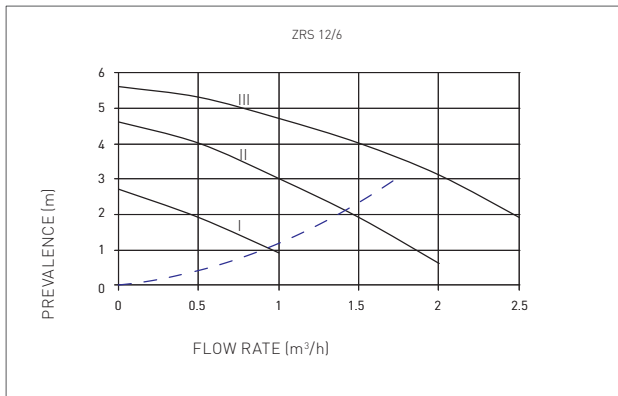

fig.1

1.1.7. RECIRCULATION MODE PUMP HEAD / FLOW DIAGRAM



III — Pump priority maximum speed

II — Pump head at second speed

I — Pump head at minimum speed

- - - Appliance head losses

1. INSTALLATION

1.1.8. HYDRAULIC CONNECTION

**DANGER**

Make sure that the water and heating pipes are not used as grounding system for the electrical plant. They are not suitable for such use.

**WARNING**

To prevent voiding the warranty and ensure proper operation of the water heater, please wash the system (if possible when hot) with suitable pickling or descaling solutions in order to remove the impurities coming from pipes and radiators.

**WARNING**

If the water heater is installed in a hydrostatic position lower than those of the connected devices (radiators, fan coils, etc.), install the shut-off valves on the D.H.W. and heating circuits to ease the performance of the maintenance operations if it is necessary only to empty the water heater.

**WARNING**

When connecting the water heater to water supply, avoid excessive bending and recovery operations from any off axis positioning that may damage the pipes causing leaks, malfunction or early wear.

**WARNING**

In order to avoid any vibrations and noises, do not use pipes with small diameters or elbows with small radius and significant cut-off of the passage sections.

**WARNING**

Connect the water heater safety drains to a discharge funnel. The manufacturer is not responsible for any floods due to safety valve opening in case of plant overpressure.

In order to prevent limestone build-up and damages to the D.H.W. heat exchanger, the hardness of the domestic supply water should not exceed 15 °f. However, please check the characteristics of the water used and install suitable treating devices.

The heat exchanger coil cleaning frequency depends on the hardness of the supply water and on the presence of solid residues or impurities inside the water that are often present in case of recently installed plants. Based on the characteristics of the inlet water, the installation of suitable water treating devices is recommended, for residues presence please install a line filter.

The pressure of the cold inlet water should be between 0.5 and 6 bar. In case of higher pressure values, please install a pressure reducer upstream from the water heater.

1. INSTALLATION

1.1.9. RECIRCULATION MODE

The tankless water heater has within, as standard, a recirculation system c/w circulating pump which is aimed to provide a better well-being for the domestic hot water needs, thus delivering immediately a large amount of hot water.

To activate the recirculation mode, please proceed as follows:

- > turn the diverter valve onto the position "recirculation", as shown 'RC' in figure 1.
- > activate the recirculation mode by pressing simultaneously the **R** and **-** buttons of the control panel (fig. 2). The activation of the recirculation mode is displayed onto the control panel by means of the 'rc' symbol.
- > adjust the setting of the return temperature by pressing **+** and **-** (fig. 3). The activation of the pump is displayed onto the control panel by means of the pump **▶** symbol.

To detect the return temperature, the system activates the pump for 20 seconds every 10 minutes.

If the temperature detected therein, by the recirculation sensor, is lower than the required one, the pump activates and the appliance operates at the minimum fire rating.

When the required temperature is achieved, the appliance shuts-off and the pump runs for 40 seconds (this latter value can be adjusted by means of parameter P04). The highest possible temperature of the hot water, during the recirculation mode, is of 53 °C.

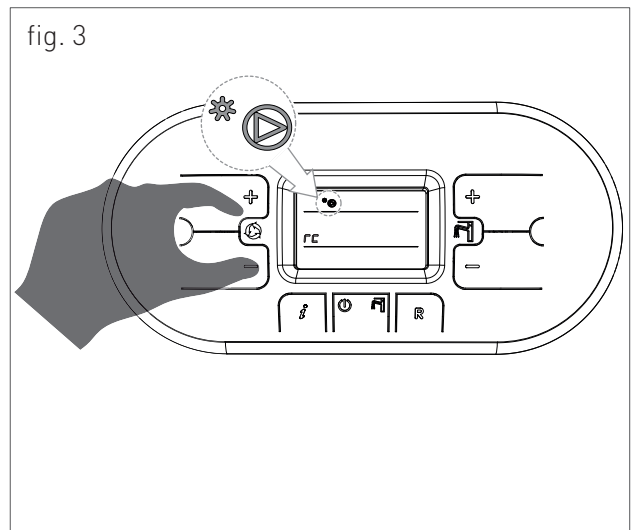
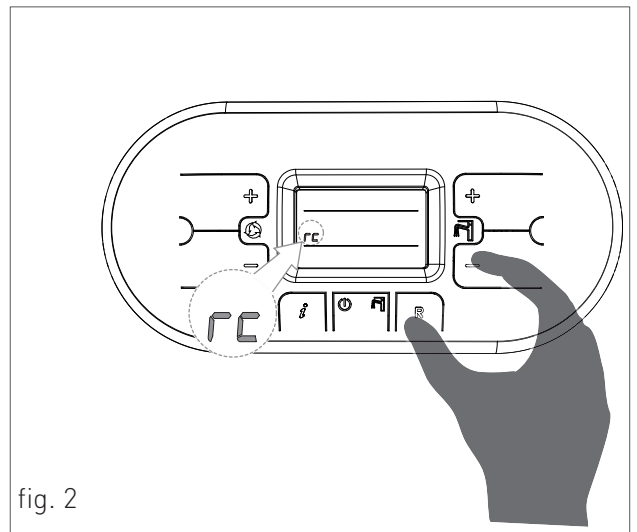
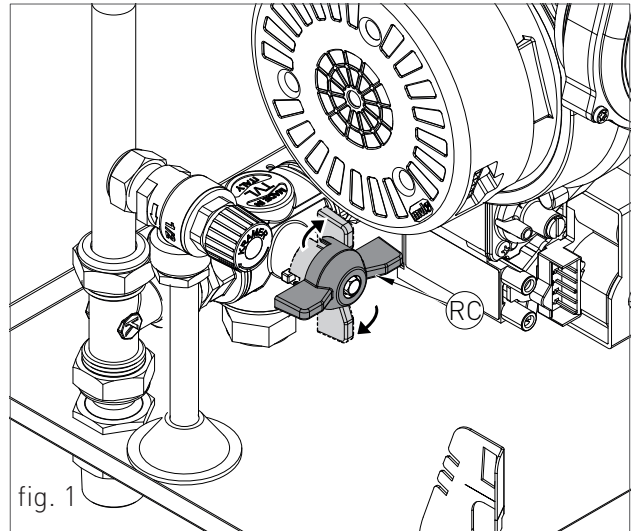

1.1.10. D.H.W. PRODUCTION THRU A REMOTE TANK

The water heater can also actually feed a remote tank meant for the D.H.W. (domestic hot water) storage. The pump integrated within the water heater, designed ex-factory for the recirculation loop, can load the external tank. This leads to a larger D.H.W. production to satisfy multiple draws from the taps.

To activate this function, please proceed as follows:

- › Turn the three-way valve to the “recirculation” position, as shown in Figure 1 as ‘RC’.
- › Arrange the hydraulic connections as per the scheme ‘D.H.W. PRODUCTION THRU A REMOTE TANK’, as per chapter ‘HYDRAULIC BOARD’.
- › Disconnect the two faston of the recirculation probe (see B-fig. 2), and connect them onto the optional probe meant for the storage (part number: 40-00324, see fig. 2). Insert this latter probe into the sensor-holder of the storage tank.
- › Enter the menu parameters and set the value of the parameter P02 to ‘1’ = STORAGE TANKLESS (see chapters ‘DIGITECH CS PARAMETERS TABLE’ and ‘ACCESSING AND PROGRAMMING THE PARAMETERS’);
- › Set the temperature setpoint of the D.H.W. tank by pressing **+** and **-** the sanitary  (fig. 3).

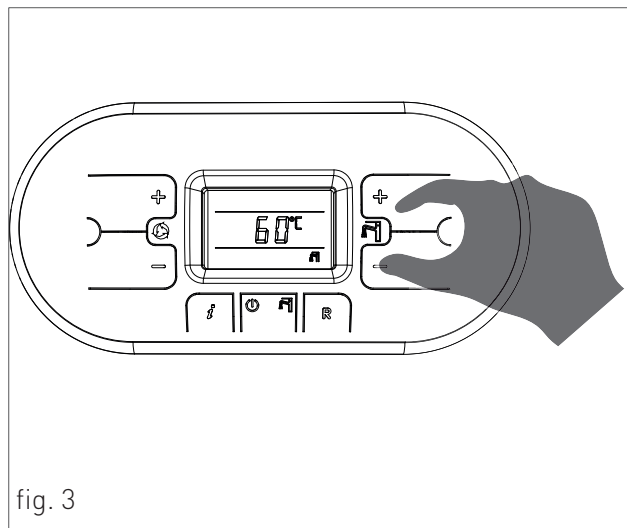
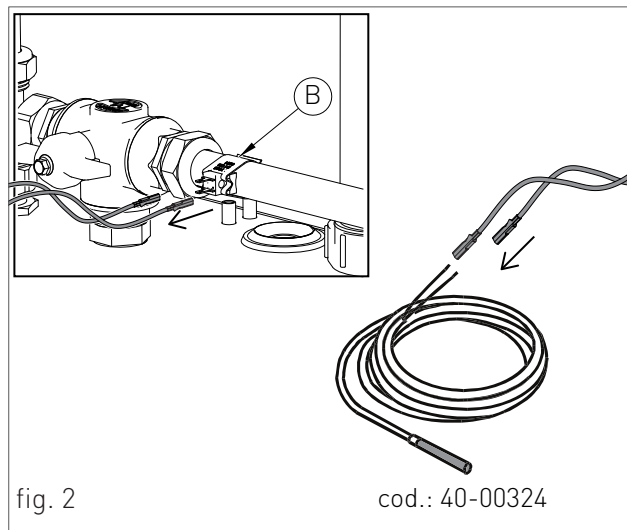
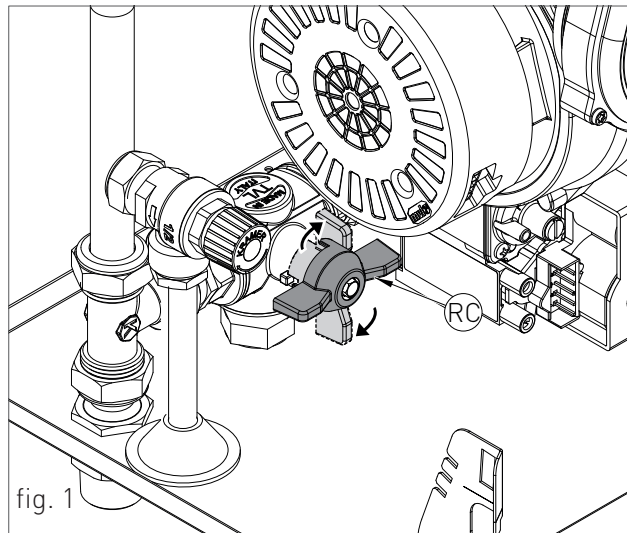

1. INSTALLATION

1.1.11. FILLING THE CONDENSATE COLLECTION SIPHON

Before starting the water heater you have to fill the condensate collection siphon in order to avoid flue reflux through the siphon.

Fill the condensate collection siphon as follows (see fig. 1):

- > With a glass pour the water in the heat exchanger's flue exhaust duct outlet (see fig. 1), up to fill the condensate trap to the highest point "T" (fig. 1);
- > Connect the dedicated flexible condensate draining tube to a waste disposal system. The condensate can be drained directly in the sewerage system by inserting an easily serviceable siphon.

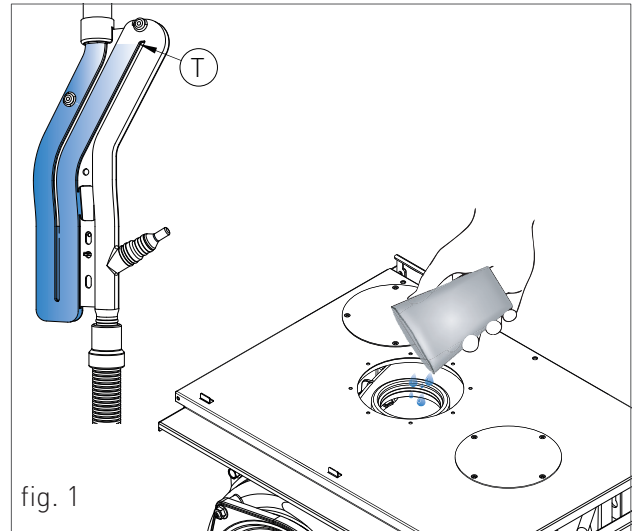

1.1.12. ANTI-FREEZE PROTECTION

The water heater is protected against freezing thanks to the electronic board preparation with functions that start the burner and heat the concerned parts when their temperature goes below the minimum pre-set values, protecting the water heater up to an external temperature of -10°C.

The device starts when the hot water temperature goes below 5 °C, automatically starting the burner until the water reaches the temperature of 15 °C.

The system starts even if on the display appears "OFF", as long as the water heater is connected to the power (230 V) and gas supply.

For long periods of standby, please empty the water heater.

If the temperature goes below -10 °C please insert electrical resistances kit (cod. 82259LP).

1. INSTALLATION

1.1.13. GAS CONNECTION



DANGER

In order to connect the gas connector of the water heater to the supply pipe use a stop seal of an appropriate size and material. The use of hemp, teflon tape or similar materials is strictly forbidden.

BEFORE PERFORMING THE GAS CONNECTION, MAKE SURE THAT:

- › the gas adduction line complies with the standards and regulations in force;
- › the tubing's section suits the requested capacity and its length;
- › the tubing is equipped with all safety and control devices required by the standards in force;
- › the internal and external seals of the gas infeed plant are checked;
- › the device is suitable for use with the type of gas available by checking the water heater data plate (placed on the inner side of the front casing. If they do not match you must take the necessary measures to adapt the water heater to another type of gas (see chapter GAS TRANSFORMATION);
- › the gas supply pressure falls within the values indicated on the data plate.

1.1.14. ELECTRICAL CONNECTION



DANGER

The equipment is electrically safe only if it is properly connected to an efficient grounding system, performed in compliance with the safety standards in force. You should check this essential safety requirement. If in doubt, request an accurate check of the electrical system performed by qualified staff, as the manufacturer is not responsible for any damages caused by lack of grounding system.

- › Make sure that the electrical systems is suitable for the maximum power absorbed by the equipment, value indicated on the data plate.
- › make sure that the cables section is appropriate for the maximum power absorbed by the equipment and that it is however not lower than 1 mm².
- › The equipment works with alternating current of 230 V and 50 Hz. The electrical connection must be performed using an all-pole switch with an opening of at least 3 millimetres between contacts placed upstream from the device.



WARNING

Make sure that the phase and neutral cables connection is performed in compliance with the wiring diagram (see chapter POWER SUPPLY).



WARNING

It is strictly forbidden the use of adaptors, multiple plugs and/or extensions for the general power supply of the equipment from the electrical network.

1.1.15. POWER SUPPLY

To power the water heater connect the electrical cables to the terminal inside the control panel as follows:

**DANGER**

Cut off the voltage from the main switch.

- > remove the water heater's front casing (refer to chapter ACCESSING THE WATER HEATER).
- > loosen the two screws and remove the plate "A" (see fig. 1).
- > after removing the plate, connect the electrical cables to terminal "B" (see fig. 1):
 - the yellow/green cable to the terminal marked with grounding symbol "⏏".
 - the blue cable to the terminal marked with "N".
 - the brown cable to the terminal marked with "L".

After performing these operations, remount plate "A" and the front casing.

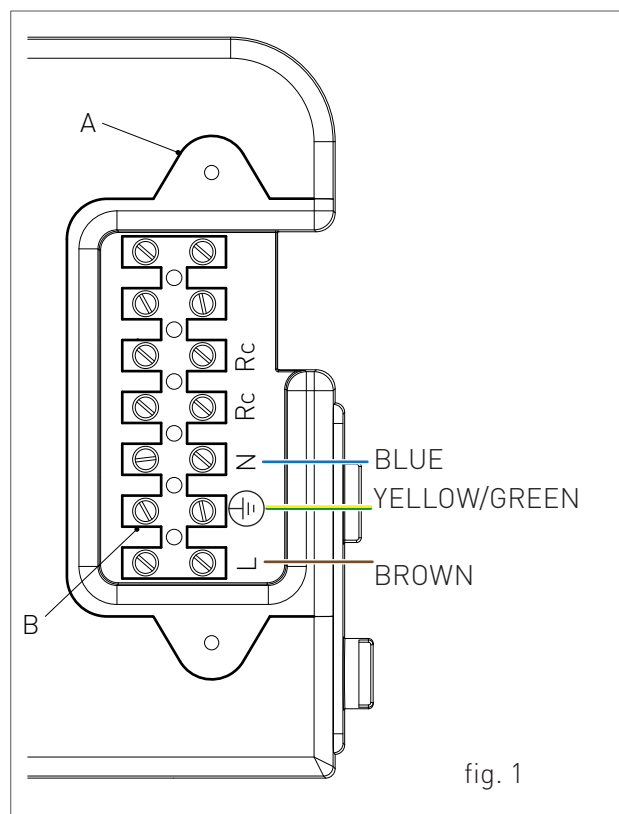

1. INSTALLATION

1.1.16. OPTIONAL ELECTRICAL CONNECTIONS

The cables should be inserted inside the water heater using the cable glands 'P1' and 'P2' placed under the board (see fig. 1). Make a hole on the cable gland, smaller than the cable diameter, to make sure that the air cannot pass through.

To wire the optional below:

(TP) DOMESTIC HOT WATER PRE-HEATING DEACTIVATION TIMER

use the terminal placed inside the control panel as follows:



DANGER

Cut off the voltage from the main switch.

- > remove the front casing of the water heater (see chapter ACCESSING THE WATER HEATER); unscrew the screws and remove plate "A" (see fig. 2).
- > After removing the plate, connect the electrical cables to terminal "B" (see fig. 2);
- > After performing these operations, remount plate "A" and the front casing.

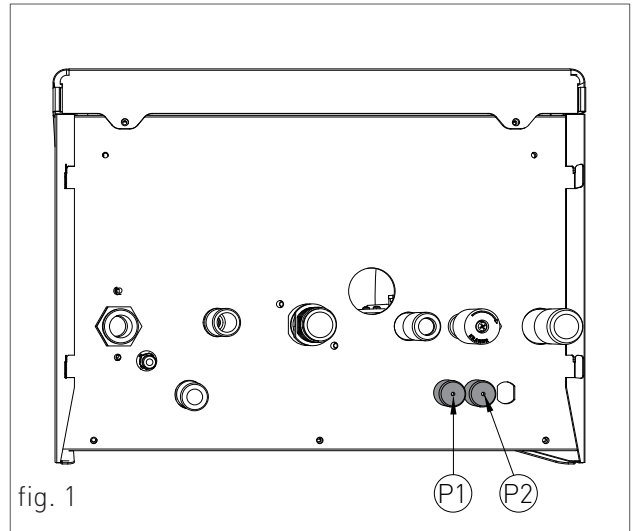

fig. 1

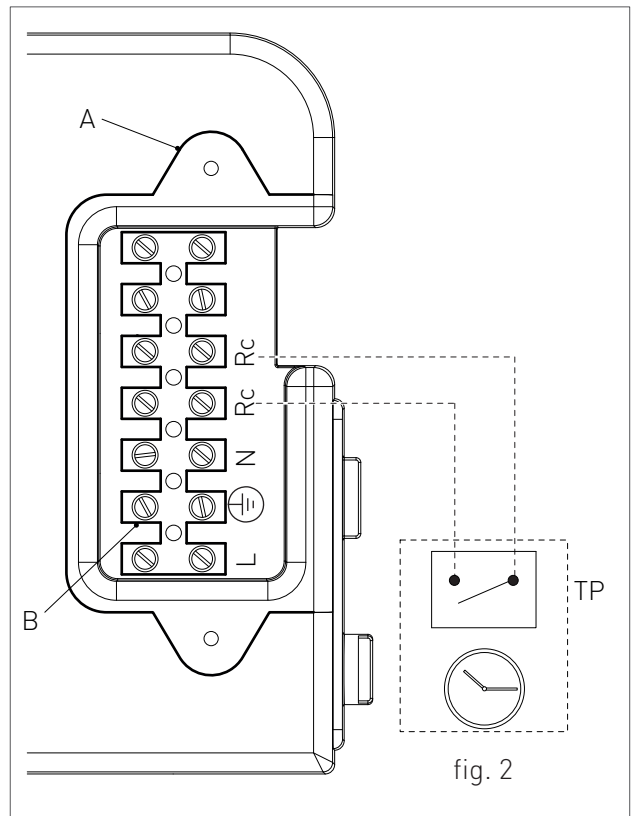

fig. 2

1. INSTALLATION

To wire the optionals below:



DANGER

Cut off the voltage from the main switch.

(CR) REMOTE CONTROL OPEN THERM

(KSI) INTEGRATED SOLAR KIT CODE 65-00915

(SIR) REMOTE INLET PROBE (SEE PROBE ENABLING AT PARAMETER P29)

› remove the boiler's front casing (refer to chapter ACCESSING THE WATER HEATER).

› remove the crankcase of the control panel (see chapter ACCESSING THE ELECTRONIC BOARD).

use the electronic board placed inside the control panel as follows:

› after removing the crankcase, connect the items below to the electronic board (see fig. 3):

After performing these operations, remount the crankcase and the front casing.

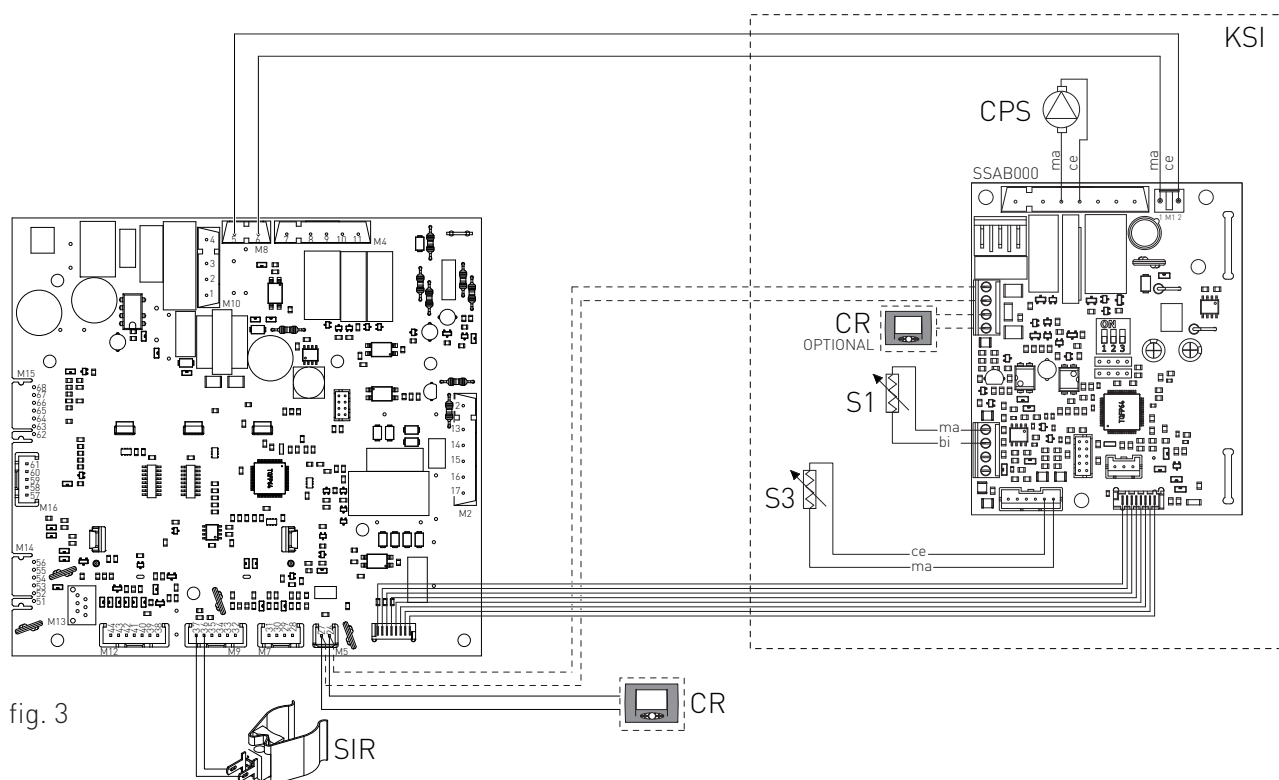

fig. 3

CPS: SOLARE PANEL PUMP

S1: SOLAR PANEL PROBE

S3: LOWER SOLAR STORAGE TANK PROBE

MA: BROWN

CE: BLUE

BI: WHITE

1. INSTALLATION

1.1.17. FUME EXHAUST FITTINGS



WARNING

In order to ensure proper operation and efficiency of the device you have to connect the water heater fume exhaust fitting to the fume exhaust duct using appropriate polypropylene flue fittings for condensing water heaters.



WARNING

You cannot use traditional flue fittings for the discharge ducts of the condensing water heaters, nor vice versa.



WARNING

For fumes exhaust and condensate collection, please follow the technical standards in force.

For all discharge ducts, with regard to the fumes path, you should provide an uphill slope (outwards) so as to favour the reflux of the condensate towards the combustion chamber, suitably realized to collect and drain acid condensate.

- › For all air suction ducts, with regard to the air path, you should provide an uphill slope (towards the water heater) so as to avoid the protrusion inside the duct of rain water, dust or foreign objects.
- › In case of horizontal co-axial system installation, correctly place the horizontal co-axial terminal suitably realized to respect the slopes inside the fumes duct and to protect the air suction duct from adverse weather conditions.
- › In order to discharge the fumes through a fumes exhaust duct carefully follow the technical standards in force.
- › Make sure that the discharge tube does not protrude inside the fumes exhaust duct, stop before it reaches the inner surface of the latter.

- › The discharge duct must be perpendicular with the opposite internal wall of the chimney or of the fumes exhaust duct (fig. 1).

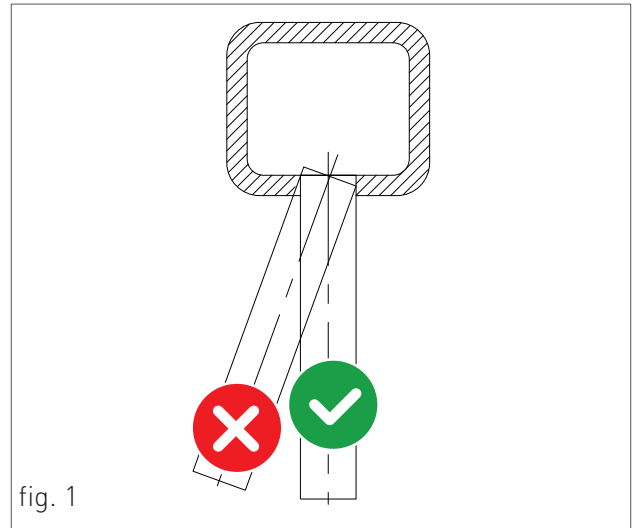

fig. 1

1. INSTALLATION

1.1.18. INSTALLATION MODES

For this type of water heater are available the following fumes discharge configuration (see fig.1):

- › B23P- Indoor suction and outdoor discharge, with exhaust system operating under pressure.

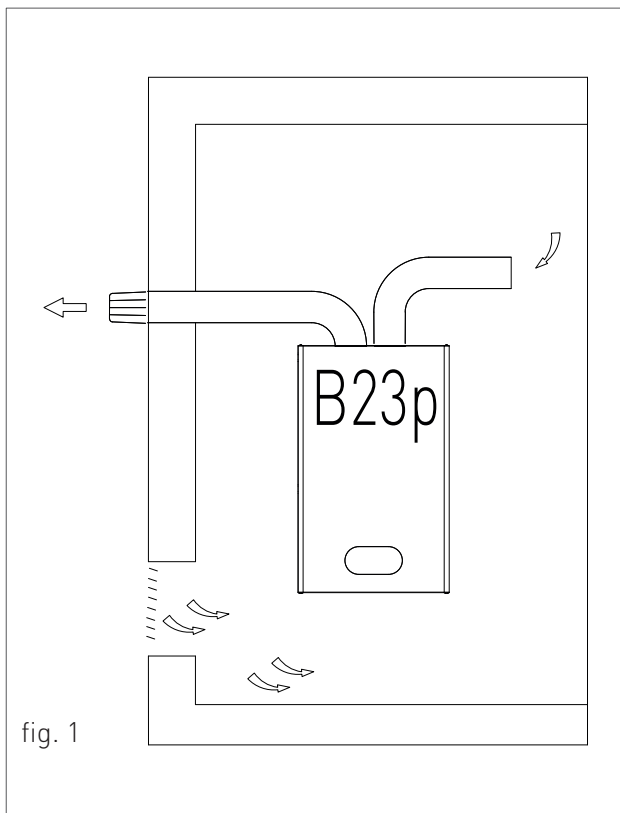

DISCHARGE OF COMBUSTION PRODUCTS FOR B-TYPE DEVICES

The gas devices, provided with connection for fumes exhaust tube, must be directly connected to efficient chimneys or fume exhaust ducts: only if these are missing you can discharge the combustion products directly through the wall.

The connection to the chimney or to the fume exhaust ducts must respect the following requirements:

- Be sealed and realised in materials suitable to resist normal mechanical stress, heat,

the action of combustion products and any condensate forming;

- have no more than three changes in direction, including the chimney and/or fume exhaust duct inlet connection, made with internal angles greater than 90°. The changes in direction must be made only by using curved elements;
- have the axis of the inlet end perpendicular to the internal wall opposite to the chimney or fume exhaust duct;
- have, along its entire length, a section equal to or greater than that of the connection of the device discharge tube;
- have no shut-off devices (shutters).
- for direct external discharge there must be no more than two changes in direction.

LOCATIONS VENTING FOR B-TYPE DEVICES

The locations in which are installed gas devices must be vented so as to ensure the amount of air necessary for a regular combustion and for location ventilation. The natural air intake must take place directly through:

- permanent openings on the external walls of the location (windows);
- single or collective, ramified ventilation ducts.

The openings on the external walls of the location must respect the following requirements:

- have a net overall free passage section of at least 6 cm² for every kW of heat capacity installed with a minimum of 100 cm²;
- they must be realized so as to make sure that the opening inlets are not obstructed (neither indoors nor outdoors);

1. INSTALLATION

- they must be protected with grids, metal meshes, etc. so as to keep the useful section mentioned above.
- they must be placed at a height next to the floor level such as to allow proper operation of the combustion products discharge systems; if such position can not be obtained, please increase by at least 50% the section of the vents.

1.1.19. TYPES OF FUME EXHAUST SYSTEMS

KIT RAIN - Ø 80 HORIZONTAL POLYPROPYLENE PIPE. OUTSIDE INSTALLATION

It allows the flue discharge through the exhaust pipe and the air intake from the environment.

Suitable only for condensing water heaters.

It allows the combustion flues discharge through a polypropylene pipe and the air exhaust directly from the hole situated on the room sealed chamber plate protected by a metal net.

PLEASE SEE THE MAXIMUM DISCHARGE LENGTH IN THE TABLE IN CHAPTER "TECHNICAL DATA".

The maximum discharge length (or linear reference length) can be calculated summing the length of the linear tube and that equivalent to each additional curve with respect to the first.

Subsequent addition of a curve is similar to adding a linear length of tube according to the indications below:

co-axial curve Ø80 to 90° = 1.5 m

co-axial curve Ø80 to 45° = 0.8 m

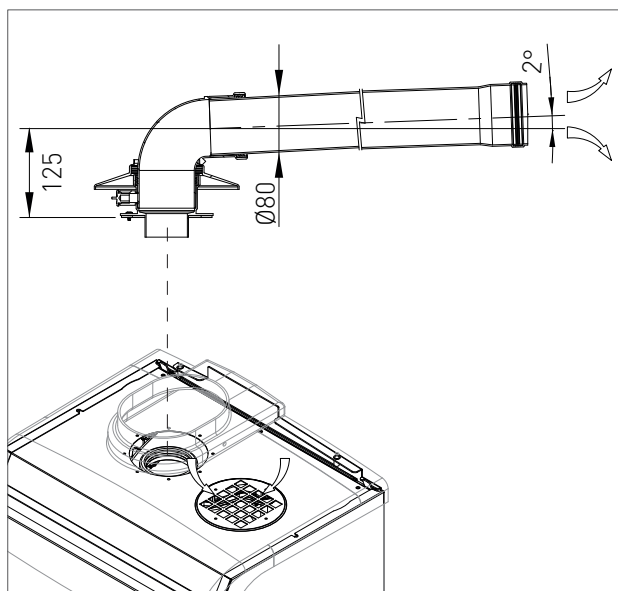

1. INSTALLATION

KIT RAIN L - Ø 80 VERTICAL POLYPROPYLENE PIPE. OUTSIDE INSTALLATION

It allows the flue discharge from the roof e and the air input from the environment.

Suitable only for condensing water heaters.

It allows the combustion flues discharge through a polypropylene pipe and the air exhaust directly from the hole situated on the room sealed chamber plate protected by a metal net.

PLEASE SEE THE MAXIMUM DISCHARGE LENGTH IN THE TABLE IN CHAPTER "TECHNICAL DATA".

The maximum discharge length (or linear reference length) can be calculated summing the length of the linear tube and that equivalent to each additional curve with respect to the first.

Subsequent addition of a curve is similar to adding a linear length of tube according to the indications below:

co-axial curve Ø80 to 90° = 1.5 m

co-axial curve Ø80 to 45° = 0.8 m

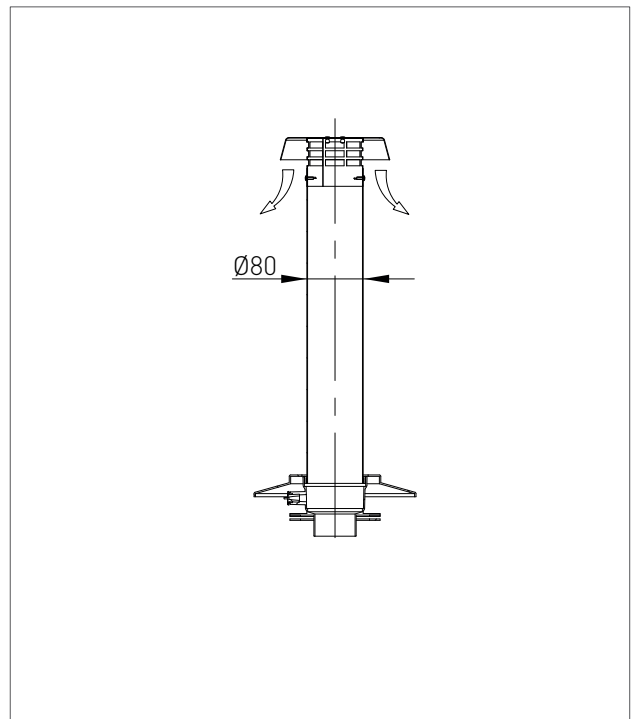
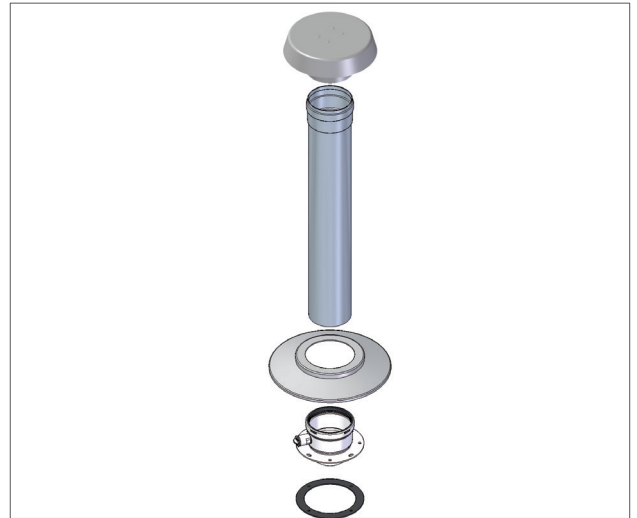

1. INSTALLATION

**FRONTAL FLUE KIT FOR RAIN SERIES - Ø 60
POLYPROPYLENE HORIZONTAL PIPE FOR
OUTDOOR INSTALLATIONS WITHOUT FLUE
CHIMNEY.**

Suitable only for condensing boilers.

It allows the outside combustion flues discharge through a polypropylene pipe, and the air intake directly from the hole which is situated on the room sealed chamber plate, which is protected by a wire mesh.

PLEASE NOTE: during the flue analysis tests, place the analyser inside the frontal flue kit terminal slots 'F' (fig. 2).

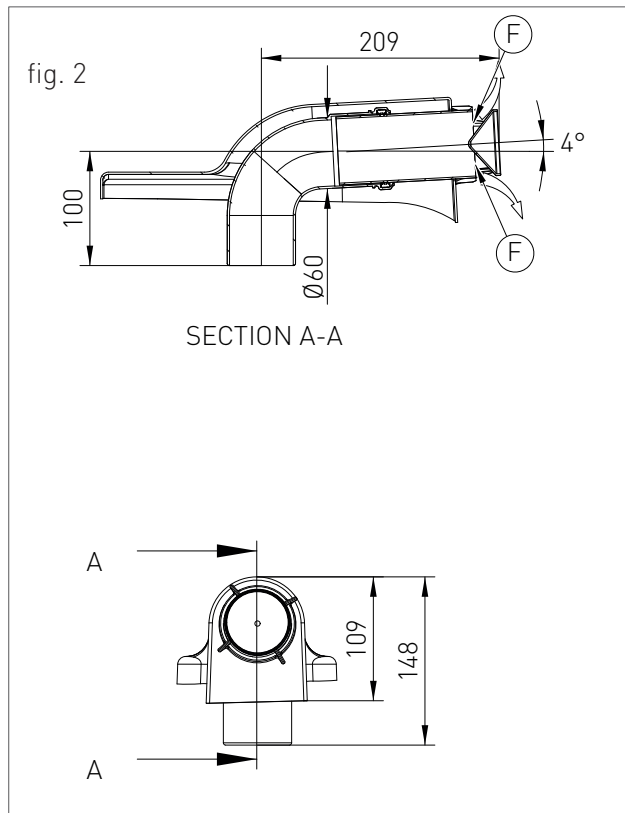
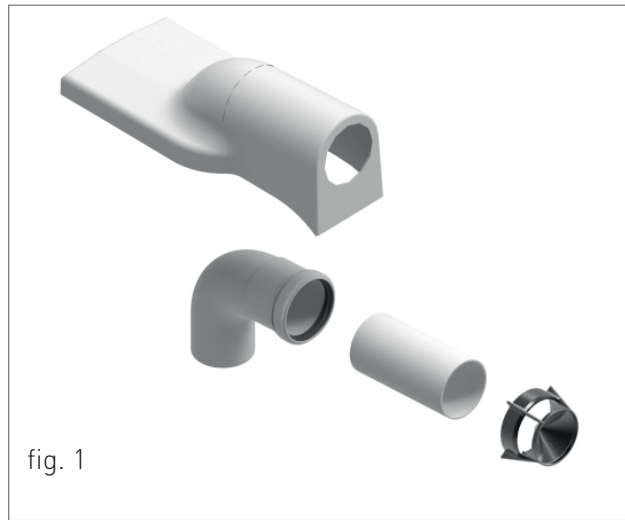

2. SUPPORT CENTER SECTION

All operations described below relative to first start-up, maintenance and replacement should be performed only by qualified personnel

2.1. FIRST START-UP

2.1.1. PRELIMINARY OPERATIONS FOR FIRST START-UP

The first start-up operations consist in checking the correct installation, adjustment and operation of the device. Proceed as follows:

- › check the inner system sealing in accordance with the indications provided by standard and regulations in forced;
- › check if the gas used is suitable for the water heater;
- › check if the gas capacity and relative pressures comply with those on the plate;
- › check the intervention of the safety device in case of lack of gas;
- › make sure that the device supply voltage corresponds with that on the plate (230 V – 50 Hz) and that the wiring is correct;
- › make sure that the grounding system works properly;
- › make sure that the combustion air adduction and fumes and condensate discharge take place properly in compliance with the Local and National Laws and Standards in force;
- › make sure that the fumes discharge tube and its connection to the fume exhaust duct comply with the requirements of the Local and National Laws and Standards;
- › make sure that the heating system gate valves are open;
- › make sure that there is no intake of gaseous products within the system;
- › make sure that there are no flammable liquids or materials near the device;
- › open the water heater gas tap and make sure that there are no gas leaks upstream from the device (the burner gas connection must be checked while the machine is running);
- › in case of new installation of the gas supply network, the air inside the tubes may block the device at its first start-up. You might have to repeat the start-up procedure to purge all the air inside the tube.

2.1.2. WATER HEATER COMMISSIONING

Proceed with water heater commissioning as follows:

- › power the water heater;
- › open the gas tap;
- › ignite the unit by pressing the button ;
- › open the D.H.W. taps at the maximum flow rate;
- › the unit is ignited.



WARNING

Please make sure all the air is flushed-off by means of the drain valve located within the unit (A - figure 1) and thru the air separator plug (B - figure 1).

- › If the flame is missing the board will repeat the start-up operations after post-ventilation (20 seconds).
- › You might have to repeat the start-up operation several times to release all air inside the gas tube. Before repeating the operation, wait at least 5 seconds from the last start-up attempt and unlock the water heater from "E01" error code by pressing the Reset  key.

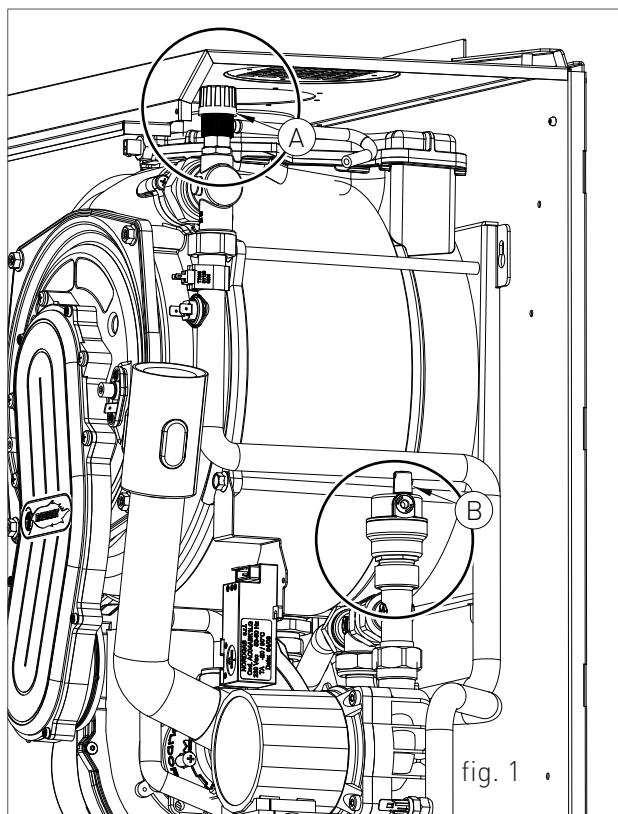

2.1.3. CO₂ VALUE CHECK AND CALIBRATION



WARNING

The CO₂ value should be checked with the casing assembled, while the gas valve should be adjusted with the casing open.

To check and calibrate the CO₂ value to minimum and maximum power proceed as follows:

FOR MINIMUM POWER

- › Access parameter 'P06' following the procedure described in chapter "ACCESSING AND PROGRAMMING THE PARAMETERS" and stay in edit mode until the calibration is completed (the maximum time before forced exiting the edit mode is 7 minutes).
- › Open several D.H.W. taps at the highest flow rate.
- › Insert the fumes analyser probe in the suitable 'PF' fumes inlet (fig. 1), then make sure that the CO₂ value complies with the requirements indicated in chapter "Technical data", otherwise unscrew the protection screw 'A' (fig. 2) and adjust using a 4 Allen wrench the screw '2' (fig. 2) of the Off-Set adjuster. To increase the CO₂ value, turn the screw clockwise and vice-versa if you want to decrease it.
- › Once completed the adjustment, tighten the protection screw 'A' (fig. 2) on the Off-Set adjuster.
- › Exit parameter 'P06' following the procedure described in chapter "ACCESSING AND PROGRAMMING THE PARAMETERS".

FOR MAXIMUM POWER

- › Open several D.H.W. taps at the highest flow rate.

- › Access parameter 'P07' following the procedure described in chapter "ACCESSING AND PROGRAMMING THE PARAMETERS" and stay in edit mode until the calibration is completed (the maximum time before forced exiting the edit mode is 7 minutes).
- › Then make sure that the CO₂ value complies with the indications in "Technical data", otherwise adjust using screw '1' (fig. 2) of the gas flow adjuster. To increase the CO₂ value, turn the screw anti-clockwise and vice-versa if you want to decrease it.
- › After each adjustment variation on screw '1' (fig. 2) of the gas flow adjuster you have to wait for the water heater to stabilize itself to the set value (about 30 seconds).
- › Enter again the parameter P06 and make sure that the CO₂ value did not change to minimum, if changed repeat the calibration described in the previous paragraph.

fig. 1

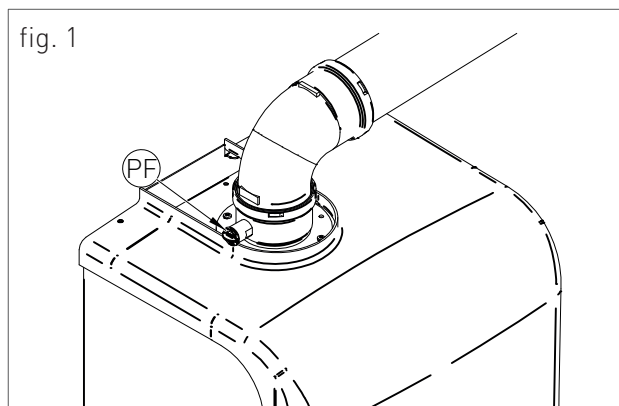
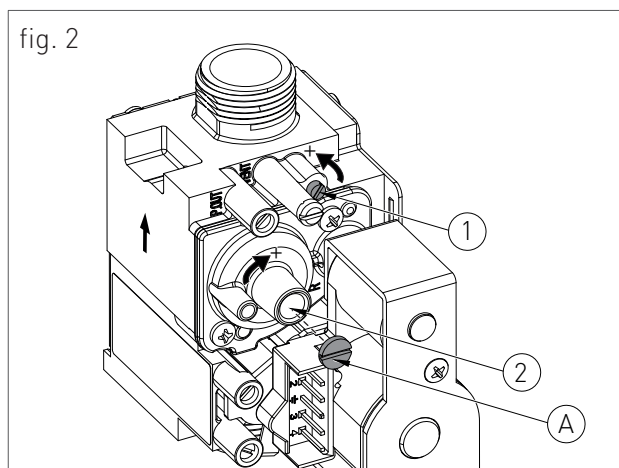

fig. 2







2.1.4. ACCESSING AND PROGRAMMING THE PARAMETERS

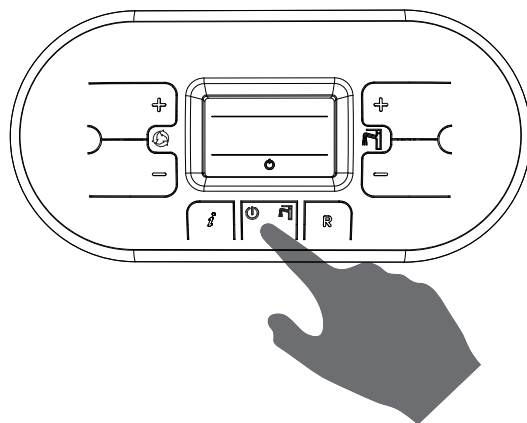

To access the parameters menu and adjust their values, follow the procedure below:

1. Press the button  to select the OFF mode displayed using the symbol .

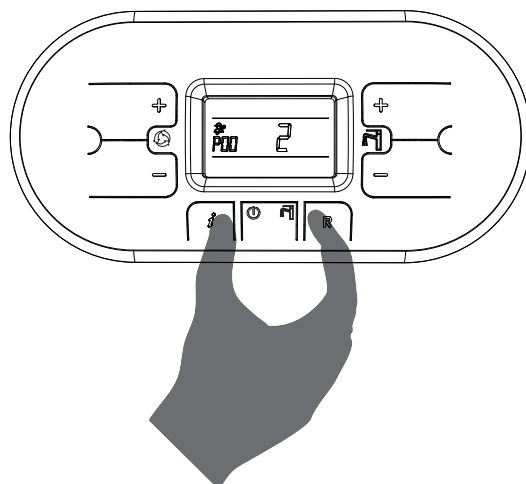

2. Hold at the same time the keys  and  until on the display appears the symbol  with the message 'P00', and release the keys  and .



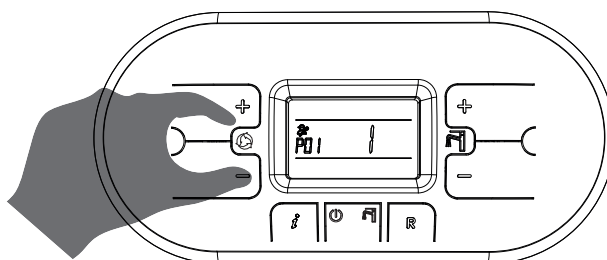

3. Use the keys  and  of the symbol recirculation  to select the parameter to be edited.





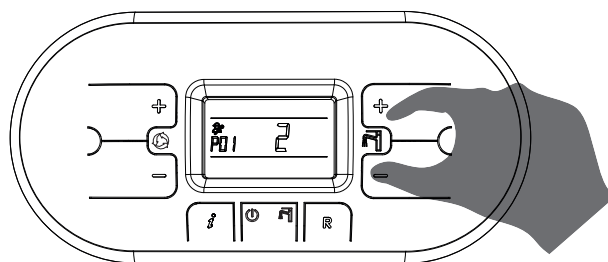

2. FIRST START-UP

4. Use the keys '+' and '-' of the domestic circuit  to change the value of the parameter.

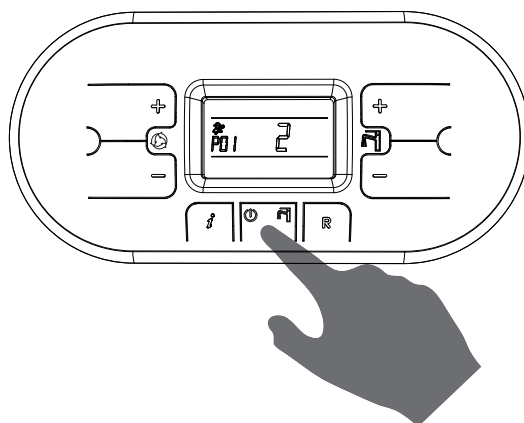

5. Press the key  to confirm the action and wait for the display to stop blinking, indication of the fact that the adjustment was implemented.



6. To exit the parameters menu, hold at the same time the keys  and  and wait for the symbol  to appear on the display.

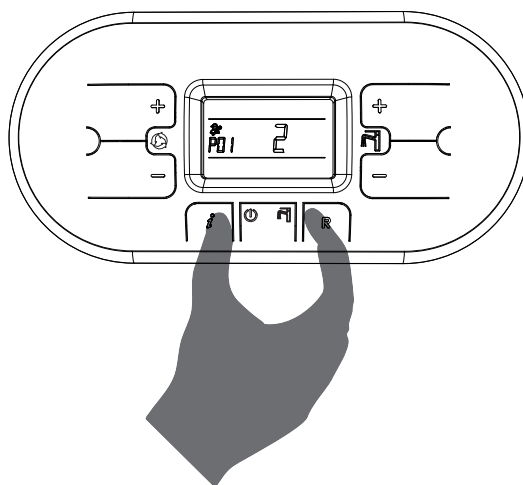

2.1.5. DIGITECH CS PARAMETERS TABLE

PARAMETER	DESCRIPTION	RANGE	FUNCTION
P00	SELECTION OF THE FIRE RATING	0 - 3	0 = 24 KW 1 = 28 KW 2 = 34 KW 3 = 50 KW
P01	GAS TYPE SELECTION ATTENTION: READ THE INSTRUCTION IN CHAPTER 'GAS TRANSFORMATION' BEFORE CHANGING THIS PARAMETER.	0 - 1	0 = NATURAL GAS 1 = LPG
P02	WATER HEATER TYPE SELECTION	0 - 2	0 = INSTANTANEOUS 1 = REMOTE STORAGE TANK 2 = INTEGRATED STORAGE TANK
P03	POST-CIRCULATION TIMING (RECIRCULATION MODE NON ACTIVE) THROUGH THIS PARAMETER YOU CAN SET THE PUMP OPERATION DURATION ON THE DOMESTIC CIRCUIT, AFTER THE TAP IS CLOSED.	0 - 90	VALUE EXPRESSED IN MULTIPLES OF 5 SECONDS (PRESET AT 12 X 5 = 60 SECONDS)
P04	POST-CIRCULATION TIMING (RECIRCULATION MODE ACTIVE) THROUGH THIS PARAMETER YOU CAN SET THE PUMP OPERATION DURATION ON THE DOMESTIC CIRCUIT, WHEN THE RECIRCULATION MODE IS ACTIVE, AFTER THE TAP IS CLOSED.	0 - 90	VALUE EXPRESSED IN MULTIPLES OF 5 SECONDS (PRESET AT 8 X 5 = 40 SECONDS)
P05	RECIRCULATION DIFFERENTIAL ACTIVATION THROUGH THIS PARAMETER YOU CAN ANTICIPATE THE RECIRCULATION FUNCTION, COMPARED TO THE RECIRCULATION SET POINT PRESET BY THE END-USER, BY MODIFYING THE TEMPERATURE DIFFERENCE.	5 - 15	VALUE EXPRESSED IN °C

2. FIRST START-UP

PARAMETER	DESCRIPTION	RANGE	FUNCTION
P06	<p>FAN MINIMUM SPEED ADJUSTMENT</p> <p>THROUGH THIS PARAMETER YOU CAN SET THE FAN MINIMUM SPEED CORRESPONDING TO THE MINIMUM POWER OF THE BURNER.</p> <p>THE VALUE IS PRE-SET BASED ON THE SET POWER (SEE PARAMETER P00) AND ON THE GAS TYPE (SEE PARAMETER P01).</p>	43 - 255	VALUE EXPRESSED IN HERTZ (1HZ = 30 RPM)
P07	<p>FAN MAXIMUM SPEED ADJUSTMENT</p> <p>THROUGH THIS PARAMETER YOU CAN SET THE MAXIMUM FAN SPEED CORRESPONDING TO THE MAXIMUM POWER OF THE BURNER.</p> <p>THE VALUE IS PRE-SET BASED ON THE SET POWER (SEE PARAMETER P00) AND ON THE GAS TYPE (SEE PARAMETER P01).</p>	43 - 255	VALUE EXPRESSED IN HERTZ (1HZ = 30 RPM)
P08	<p>STARTING STEP ADJUSTMENT</p> <p>THROUGH THIS PARAMETER YOU CAN SET THE FAN SPEED DURING THE START-UP.</p> <p>THE VALUE IS PRE-SET BASED ON THE SET POWER (SEE PARAMETER P00) AND ON THE GAS TYPE (SEE PARAMETER P01).</p>	43 - 255	VALUE EXPRESSED IN HERTZ (1HZ = 30 RPM)
P09	<p>D.H.W RUN-DOWN</p> <p>THROUGH THIS PARAMETER YOU CAN SET THE TIME NECESSARY FOR THE WATER HEATER TO REACH THE MINIMUM SET POWER, AFTER THE BURNER START-UP.</p>	02 - 15	VALUE EXPRESSED IN SECONDS (PRE-SET AT 8 SECONDS)
P10	<p>TYPE OF UNIT SELECTION</p>	0 - 1	0 = °C - l/min 1 = °F - gpm
P11	<p>EXECUTION PERIOD OF THE OVERHEATING FUNCTION</p> <p>THROUGH THIS PARAMETER YOU CAN ENABLE AND SET THE DURATION OF THE EXECUTION PERIOD OF THE OVERHEATING FUNCTION, DURING WHICH THE CIRCULATING PUMP ACTIVATES BY DISSIPATING THE HEAT IN EXCESS.</p>	0 - 60	VALUE EXPRESSED IN SECONDS (PRE-SET AT 10 SECONDS)

2. FIRST START-UP

PARAMETER	DESCRIPTION	RANGE	FUNCTION
P12	ACTIVATION PERIOD OF THE OVERHEATING FUNCTION THROUGH THIS PARAMETER YOU CAN SET THE TIME INTERVAL FROM THE END OF THE POST-CIRCULATION TO THE ACTIVATION OF THE OVERHEATING FUNCTION.	0 - 20	VALUE EXPRESSED IN MINUTES (PRE-SET AT 10 MINUTES)
P13	MAXIMUM DOMESTIC SETPOINT THROUGH THIS PARAMETER YOU CAN SET THE USER-ADJUSTABLE MAXIMUM DOMESTIC TEMPERATURE.	50 - 75	VALUE EXPRESSED IN °C (PRE-SET AT 60°C)
P14	MINIMUM DOMESTIC SETPOINT THROUGH THIS PARAMETER YOU CAN SET THE USER-ADJUSTABLE MINIMUM DOMESTIC TEMPERATURE.	35 - 45	VALUE EXPRESSED IN °C (PRE-SET AT 40°C)
P15	ANTI-LEGIONELLA FUNCTION (FOR STORAGE TANK) THROUGH THIS PARAMETER YOU CAN ACTIVATE/DEACTIVATE THE "ANTILEGIONELLA" HEAT TREATMENT OF THE STORAGE TANK. EVERY 7 DAYS THE WATER TEMPERATURE INSIDE THE STORAGE IS HEATED BEYOND 60 °C THUS GENERATING A BURNING HAZARD. KEEP UNDER CONTROL SUCH DOMESTIC HOT WATER TREATMENT (AND INFORM THE USERS) TO AVOID UNFORSEEABLE DAMAGES TO PERSONS, ANIMALS AND PROPERTY. A THERMOSTATIC VALVE SHOULD BE INSTALLED AT THE DOMESTIC HOT WATER OUTLET TO AVOID ANY BURNS.	0 - 1	0 = DISABLED 1 = ENABLED
P16	DIFFERENTIAL OF THE STORAGE TANK CYCLE ACTIVATION THROUGH THIS PARAMETER YOU CAN ANTICIPATE THE PRE-HEATING FUNCTION OF THE STORAGE TANK, COMPARED TO THE D.H.W SET POINT PRE-SET BY THE END-USER, BY MODIFYING THE TEMPERATURE DIFFERENCE.	1 - 20	VALUE EXPRESSED IN °C (PRE-SET AT 5°C)
P17	MINIMUM D.H.W FLOW RATE SETTING THROUGH THIS PARAMETER YOU CAN SET THE MINIMUM D.H.W. FLOW RATE NECESSARY TO ACTIVATE THE WATER HEATER. THE VALUE IS PRE-SET BASED ON THE SET POWER (SEE PARAMETER P00).	20 - 68	VALUE EXPRESSED IN HERTZ 20 Hz = 1.5 l/min 28 Hz = 2 l/min 37 Hz = 2.5 l/min 45 Hz = 3 l/min 52 Hz = 3.5 l/min 59 Hz = 4 l/min 64 Hz = 4.5 l/min 68 Hz = 5 l/min

2. FIRST START-UP

PARAMETER	DESCRIPTION	RANGE	FUNCTION
P18	ADDITIONAL POST-VENTILATION TIMING THROUGH THIS PARAMETER YOU CAN SET A PERIOD OF OPERATION, ADDITIONAL TO THE 20 STANDARD SECONDS OF THE FAN, AFTER THE BURNER SHUTDOWN.	20 - 120	VALUE EXPRESSED IN SECONDS (PRE-SET AT 30 SECONDS)
P19	ANTI-WATER HAMMER SELECTION ONCE THIS FUNCTION IS ENABLED, THE D.H.W CONTACT WILL BE DELAYED FOR A TIME EQUAL TO THE SET VALUE.	0 - 20	0 = DISABLED 1-20 = VALUE EXPRESSED IN SECONDS
P20	DESTINATION COUNTRY SELECTION BY MODIFYING THIS PARAMETER THE COMBUSTION CONTROL PARAMETERS WILL BE AUTOMATICALLY CONFIGURATED, ACCORDING TO THE VALUES FIXED IN THE DESTINATION COUNTRY OF THE PRODUCT.	0 - 1	0 = U.S.A. / CANADA 1 = DIFFERENT COUNTRY
P21	PUMP OPERATION IN WATER HEATER MODE THROUGH THIS PARAMETER YOU CAN ACTIVATE/ DEACTIVATE THE CIRCULATING PUMP DURING THE NORMAL OPERATION OF THE WATER HEATER.	0 - 1	0 = DISABLED 1 = ENABLED
P22	ENABLING BUS INDUSTRIAL PILOTING 0 -10V THROUGH THIS PARAMETER YOU CAN ENABLE OR DISABLE THE BUS INDUSTRIAL INPUT 0-10 V TO SET THROUGH EXTERNAL BUS THE BURNER POWER OR THE DELIVERY TEMPERATURE.	0 - 2	0 = DISABLED (SET BY DEFAULT) 1 = TEMPERATURE CONTROL MODE 2 = POWER CONTROL MODE
P23	MODBUS MODE	0 - 2	0 = ENABLED 1 = ENABLED WITH SOME SETTINGS TO BE ADJUSTED FROM THE BOILER CONTROL PANEL 2 = DISABLED (SET BY DEFAULT)

2. FIRST START-UP

PARAMETER	DESCRIPTION	RANGE	FUNCTION
P24	<p>CONNECTION STATUS OF THE SOLAR AUXILIARY BOARD (FOR CASCADE WATER HEATERS)</p> <p>BY MEANS OF THIS PARAMETER, IT IS POSSIBLE TO ENABLE THE AUXILIARY BOARD FOR THE EXPANSION OF THE RESOURCES</p> <p>WHEN THE SOLAR AUXILIARY BOARD IS CONNECTED TO THE WATER HEATER BOARD AUTOMATICALLY, THE VALUE OF THIS PARAMETER BECOMES '1', BUT IF THE SOLAR AUXILIARY BOARD IS SUCCESSIVELY DISCONNECTED, THE DISPLAY OF THE CONTROL PANEL OF THE WATER HEATER WILL DISPLAY THE ERROR 'E31'. IN THIS CASE, IN ORDER TO DEACTIVATE THE ERROR 'E31', IT IS NECESSARY TO MANUALLY SET THE VALUE OF THE PARAMETER TO '0'.</p>	0 - 1	<p>0 = NOT INSTALLED</p> <hr/> <p>1 = INSTALLED</p>
P25	<p>MODBUS COMMUNICATION BAUD RATE</p> <p>BY MEANS OF THIS PARAMETER, IT IS POSSIBLE TO SELECT THE MODBUS COMMUNICATION BAUD RATE SUPPORTED BY THE SAME INTERFACE.</p>	0 - 5	<p>0 = 9600</p> <hr/> <p>1 = 1200</p> <hr/> <p>2 = 2400</p> <hr/> <p>3 = 4800</p> <hr/> <p>4 = 9600</p> <hr/> <p>5 = 19200</p>
P26	<p>MODBUS ADDRESS</p> <p>BY MEANS OF THIS PARAMETER, IT IS POSSIBLE TO SET THE ADDRESS OF THE BOARD ON MODBUS IN ORDER TO PERFORM A CASCADE SYSTEM.</p>	1 - 16	<p>BOILER NUMBERING FOR MODBUS (PRE-SET AT 1)</p>
P27	<p>SAFETY CHECK ENABLING FOR INSUFFICIENT CIRCULATION DURING IGNITION</p> <p>BY ACTIVATING THIS PARAMETER, THE CORRECT FUNCTIONING OF THE PUMP IS CHECKED AT EACH BURNER IGNITION. THIS CHECK ALLOWS TO PROTECT THE HEAT EXCHANGER AND OTHER PARTS FROM EXCESSIVE NON-DISSIPATED HEAT, IN CASE THE PUMP DOES NOT WORK PROPERLY.</p>	0 - 1	<p>0 = DISABLED</p> <hr/> <p>1 = ENABLED (SET BY DEFAULT)</p>

2. FIRST START-UP

PARAMETER	DESCRIPTION	RANGE	FUNCTION
P28	<p>CIRCUIT SELECTION FOR ANTI-LEGIONELLA FUNCTION OPERATION (STORAGE)</p> <p>THROUGH THIS PARAMETER IT IS POSSIBLE TO SELECT THE CIRCUIT IN WHICH THE ANTI-LEGIONELLA FUNCTION OPERATES, WHEN THE VALUE OF PARAMETER P15 IS ENABLED.</p>	0 - 1	<p>0= ANTI-LEGIONELLA FUNCTION ACTIVE IN STORAGE MODE ONLY (SET BY DEFAULT)</p> <p>1= ANTI-LEGIONELLA FUNCTION ACTIVE IN STORAGE AND RECIRCULATION MODE</p>
P29	<p>OPTIONAL REMOTE INLET PROBE ENABLING ('SIR' - SEE CHAPTER «OPTIONAL ELECTRICAL CONNECTIONS»)</p> <p>THROUGH THIS PARAMETER IT IS POSSIBLE TO ENABLE THE OPERATION OF THE OPTIONAL REMOTE INLET PROBE TO STOP THE BURNER IN CASE THE D.H.W. INLET TEMPERATURE IS HIGHER OR EQUAL TO THE SET-POINT.</p>	0 - 1	<p>0 = DISABLED (SET BY DEFAULT)</p> <p>1 = ENABLED</p>
P30	<p>SOLAR AUXILIARY BOARD ENABLING (FOR SOLAR SYSTEM MANAGEMENT WITH SINGLE WATER HEATER)</p>	0 - 1	<p>0 = DISABLED (SET BY DEFAULT)</p> <p>1 = ENABLED</p>
P50	SOLAR PANEL PUMP ACTIVATION SET-POINT	15 - 80	VALUE EXPRESSED IN °C (PRE-SET AT 25°C)
P51	SOLAR PANEL MAXIMUM TEMPERATURE SET-POINT	80 - 180	VALUE EXPRESSED IN °C (PRE-SET AT 110°C)

2.2. MAINTENANCE

2.2.6. GENERAL MAINTENANCE WARNINGS



DANGER

Before each components cleaning or replacement operation, ALWAYS cut off the POWER, WATER and GAS supply of the water heater.



WARNING

To ensure greater life span and proper operation of the device, during the maintenance operations use only original spare parts.



ATTENTION

To ensure the efficiency and safety of the device, the maintenance operations must be realized on an annual basis. The operations described below, are essential to the validity of the standard Flexiheat warranty and must be performed by professionally qualified personnel in accordance with current legislation

Please perform the following operations once a year:

- › check the sealing of the water components, and replace if necessary the gaskets;
- › check that the wiring is performed in compliance with the requirements in the water heater instruction manual;
- › check the wiring inside the control panel;
- › remove and clean the burner from oxidation;
- › check the integrity and the position of the sealed chamber sealing gasket;
- › check the primary exchanger, if necessary, clean it;
- › check the operation of the gas light up and safety systems. If necessary, remove and clean the flame detection and light up electrodes from incrustations paying attention to respect the distances with respect to the burner;
- › check the sealing of the gas components, and replace if necessary the gaskets;
- › visually check the flame and the condition of the combustion chamber;
- › if necessary make sure that the combustion is suitably adjusted and if required proceed as indicated in section "CO2 VALUE CHECK AND CALIBRATION";
- › periodically check the integrity of the fume exhaustion system for safety and proper operation;
- › make sure that the permanent ventilation outlets are present, correctly sized and functioning, based on the installed devices. Respect the requirements provided by Local and National legislation;
- › check the proper operation of the condensate draining system, including the devices outside the water heater such as condensate collection devices installed along the path of the fume exhaust duct or neutralization devices for acid condensate; check that the liquid flow is not obstructed and that there are no combustion gas refluxes inside the internal system;
- › check the flow and temperature of domestic hot water.

2.2.7. TECHNICAL DATA

Model		SFK 34 Rain
CE certification	no.	0476CQ0134
Gas category		II2H3B/P
Discharge type	type	B23p
Maximum nominal heat capacity in domestic circuit	kW	34
Minimum nominal heat capacity in domestic circuit	kW	4.1
Maximum combustion Performance	%	99
Minimum combustion Performance	%	99,6
Fumes temperature at nominal heat capacity	°C	49
Fumes temperature at minimum heat capacity	°C	35
CO ₂ at nominal heat capacity - G20	%	9,45 - 9,25
CO ₂ at minimum heat capacity - G20	%	9,05 - 8,85
CO ₂ at nominal heat capacity - G30	%	11,4 - 11,2
CO ₂ at minimum heat capacity - G30	%	10,75 - 10,55
CO ₂ at nominal heat capacity - G31	%	10,55 - 10,35
CO ₂ at minimum heat capacity - G31	%	9,90 - 9,70
CO at nominal heat capacity	ppm	75
Fumes mass at nominal heat capacity	g/s	14.80
Fumes mass at minimum heat capacity	g/s	1.85
Weighted Nox (0% O ₂) ppm	ppm	28
Weighted Nox (0% O ₂) mg/kWh	mg/kWh	50
Domestic circuit		
Adjustable domestic temperature	°C	35-60
Maximum pressure for domestic circuit	bar	8
Minimum pressure for domestic circuit	bar	0.5
Specific capacity in continuous service - Δt 30°C	litres/min	17.06
Dimensional characteristics		
Width	mm	420
Depth	mm	370
Height	mm	710
Gross weight	Kg	45
Water connections		
Cold water	Ø	3/4"
Hot water	Ø	3/4"
Gas	Ø	3/4"
D.H.W. circulating loop connection	Ø	3/4"
Fume exhaust fittings		
Maximum electric fan pressure available	Pa	91
Minimum electric fan pressure available	Pa	5.8
Max discharge length Ø50 - Hor duct	m	2
Max discharge length Ø60 - Hor duct	m	12
Max discharge length Ø80 - Hor duct	m	35
Max discharge length Ø50 - Vert duct	m	2
Max discharge length Ø60 - Vert duct	m	12
Max discharge length Ø80 - Vert duct	m	35

2. MAINTENANCE

Electrical specifications		
Voltage-frequency	V/Hz	230/50
Max Absorbed Power	W	123
Insulation rate	IP	X5D
Gas supply		
Nominal supply pressure - G20	mbar	20
D.H.W Max fan speed - G20	Hz	194
D.H.W Min. fan speed - G20	Hz	45
Fuel consumption - G20	m ³ /h	3.60
Nominal Supply pressure - G30	mbar	28-30
D.H.W Max fan speed - G30	Hz	184
D.H.W Min. fan speed - G30	Hz	45
Fuel consumption - G30	kg/h	2.68
Nominal Supply pressure - G31	mbar	37
D.H.W Max fan speed - G31	Hz	195
D.H.W Min. fan speed - G31	Hz	45
Fuel consumption - G31	kg/h	2.64

2.2.8. TECHNICAL ASSEMBLY

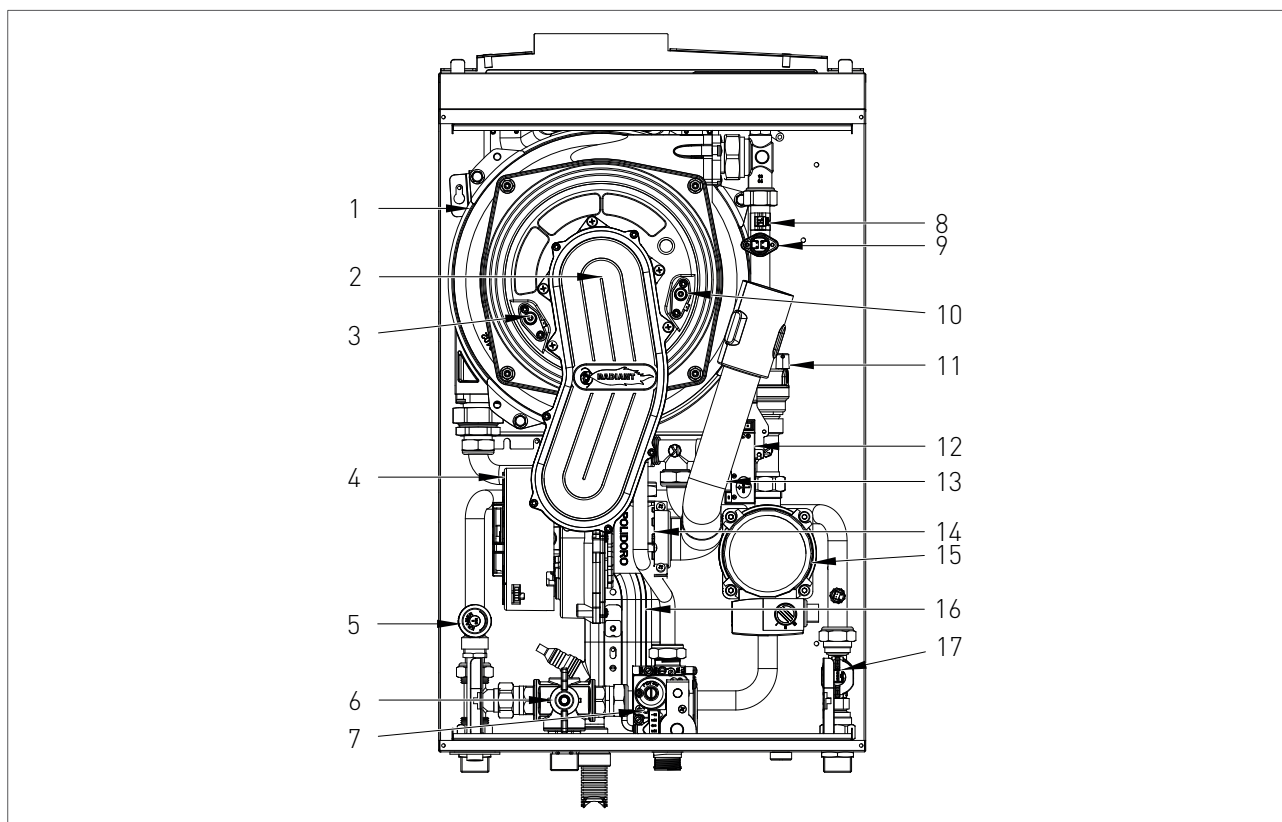

KEY

1. HEAT EXCHANGER
2. BURNER UNIT
3. DETECTION ELECTRODE
4. ELECTRIC FAN
5. SAFETY VALVE 8 bar
6. DIVERTER VALVE
7. GAS VALVE
8. DOMESTIC HOT WATER OUTLET PROBE
9. SAFETY THERMOSTAT
10. LIGHT UP ELECTRODE
11. AIR RELIEF VALVE
12. START-UP TRANSFORMER
13. AIR SUCTION TUBE
14. PROPORTIONAL VENTURI
15. CIRCULATOR
16. CONDENSATE COLLECTION SIPHON
17. FLUXMETER

2.2.9. HYDRAULIC BOARD

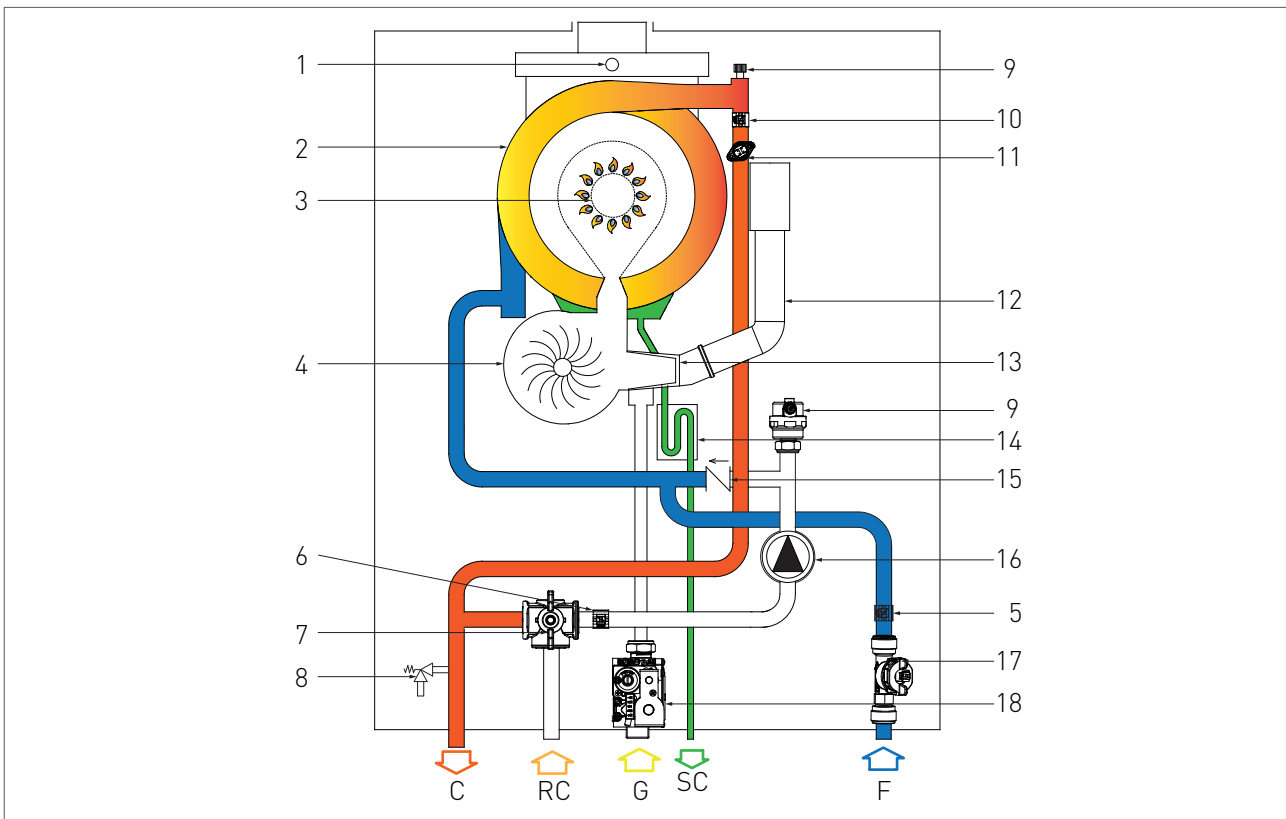

KEY

- C. DOMESTIC HOT WATER OUTLET
- RC. RECIRCULATION INLET
- G. GAS INLET
- SC. CONDENSATE DRAIN
- F. COLD WATER INLET

- 17. FLUXMETER
- 18. GAS VALVE

- 1. FUMES SAFETY THERMOFUSE
- 2. HEAT EXCHANGER
- 3. BURNER UNIT
- 4. ELECTRIC FAN
- 5. COLD WATER INLET PROBE
- 6. RECIRCULATION PROBE
- 7. DIVERTER VALVE
- 8. SAFETY VALVE 8 bar
- 9. AIR RELIEF VALVE
- 10. DOMESTIC HOT WATER OUTLET PROBE
- 11. SAFETY THERMOSTAT
- 12. AIR SUCTION TUBE
- 13. PROPORTIONAL VENTURI
- 14. CONDENSATE COLLECTION SIPHON
- 15. NO RETURN VALVE
- 16. CIRCULATOR

2. MAINTENANCE

OPERATIONAL SCHEMES

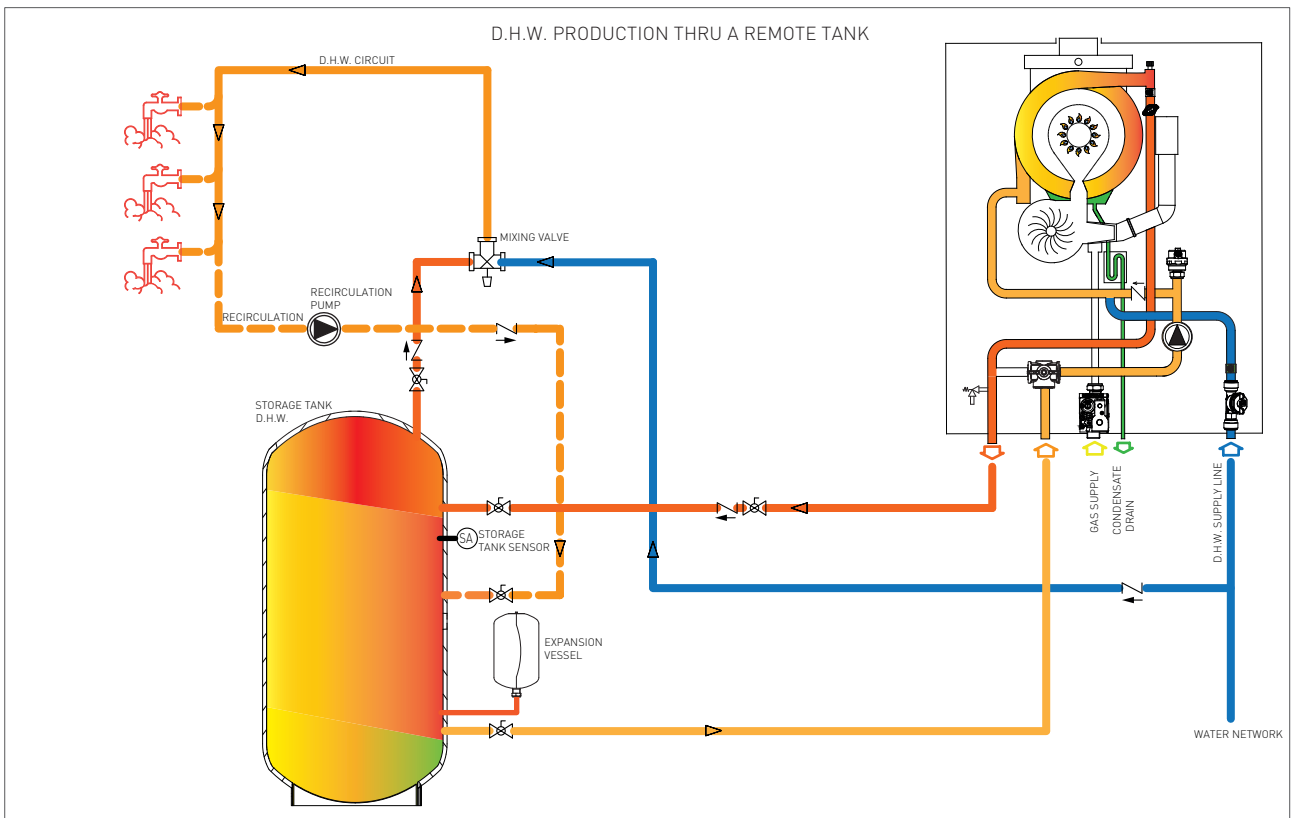
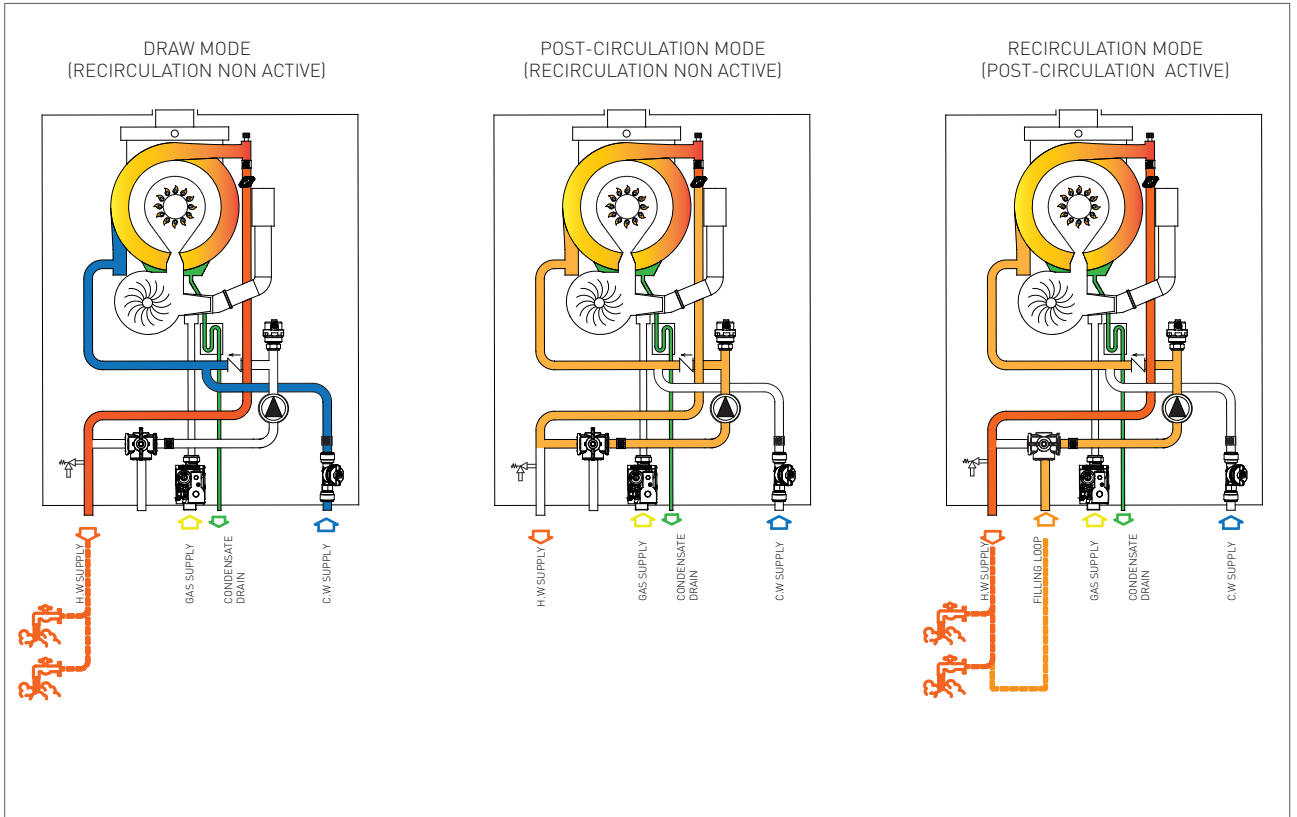

2.2.10. WIRING DIAGRAM

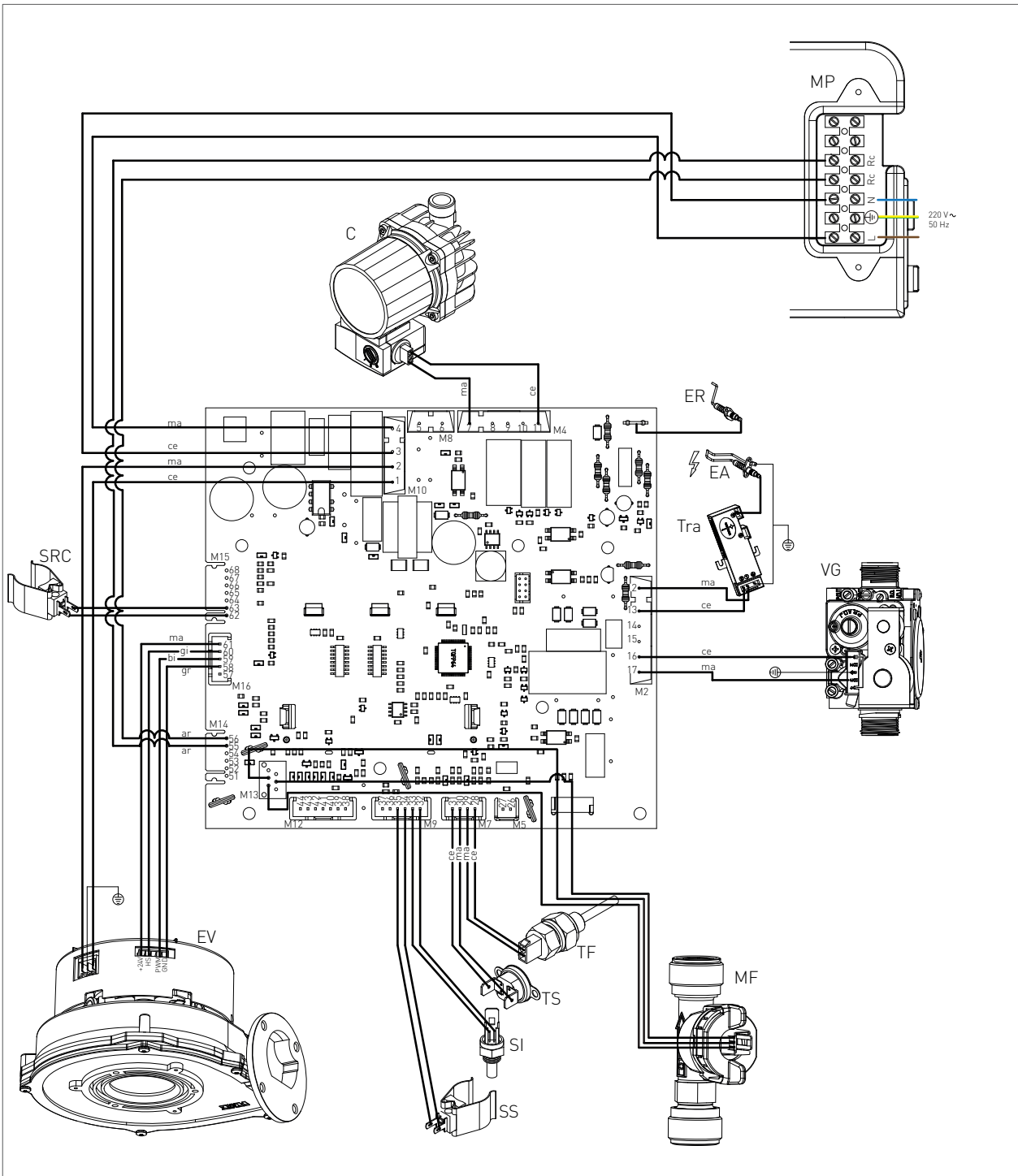

SERVICE CENTRE

ER: DETECTION ELECTRODE	TS: SAFETY THERMOSTAT	RC: DOMESTIC HOT WATER PRE-HEATING DEACTIVATION TIMER	CE: BLUE
EA: START-UP ELECTRODE	SI: DOMESTIC CIRCUIT PROBE INLET		MA: BROWN
C: CIRCULATOR	SS: DOMESTIC CIRCUIT PROBE		AR: ORANGE
VG: GAS VALVE	SRC: RECIRCULATION PROBE		GI: YELLOW
TRA: START-UP TRANSFORMER	MP: PANEL TERMINAL	L: LINE	BI: WHITE
TF: FUMES THERMOFUSE (102°C)	EV: ELECTRIC FAN	N: NEUTRAL	GR: GREY
MF: FLUXMETER		NE: BLACK	
		RO: RED	

2.2.11. ACCESSING THE WATER HEATER

For most control and maintenance operations, the panels of the casing have to be removed.

To remove the panel of the water heater, please follow the instructions below (see fig.1):

- > remove the fastening screws (1) placed on the side of the panel flange and remove it;
- > remove the fastening screws (2) placed on the upper and lower side of the panel, and remove it by pulling it towards yourself;
- > remove the fastening screws (3) placed on the lower side of the water heater and remove the connection cover.

To intervene on the front of the water heater, please proceed as follows:

- > remove the fastening screws (4) placed on the front panel;
- > grab the front panel and remove it by pulling it towards yourself;

To intervene on the side panels of the water heater, please proceed as follows:

- > remove the fastening screws (5) placed on the front edge of the side panel;
- > grab the bottom of the panel, and remove it by moving it sideways and pulling it upwards.

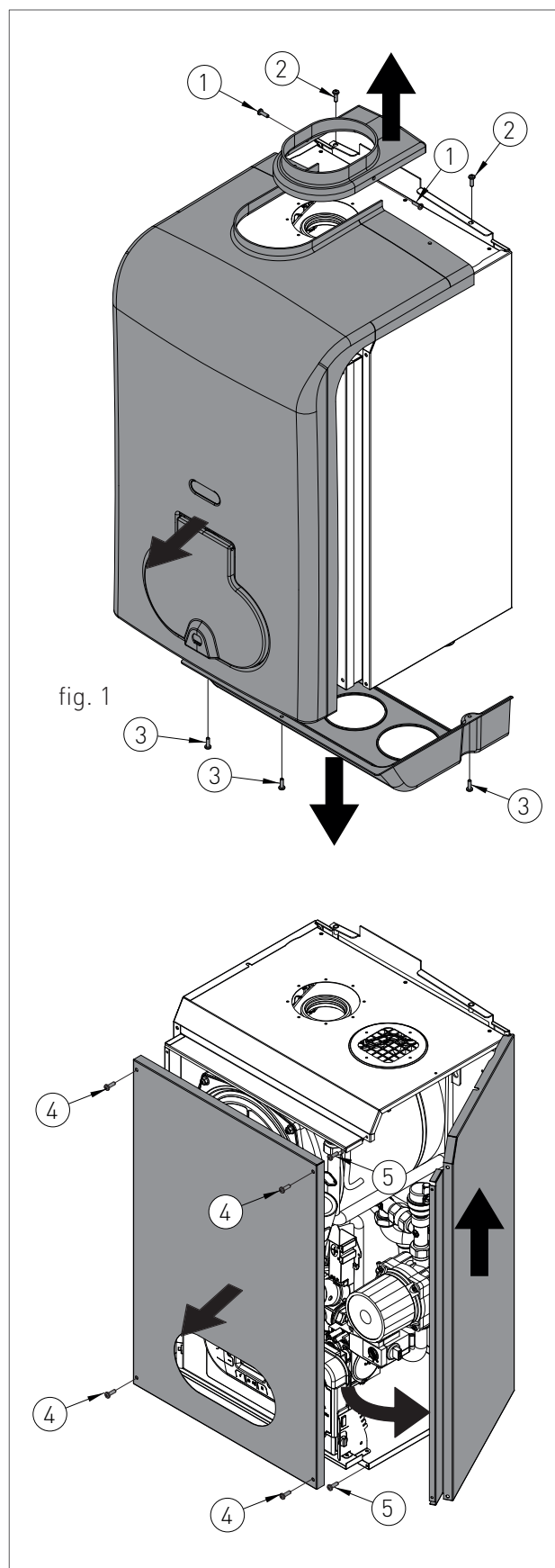

2.2.12. ACCESSING THE ELECTRONIC BOARD

In order to intervene on the wirings of the control panel, please proceed as follows:



DANGER

Cut off the voltage from the main switch.

- > Grab at the same time the support brackets of the control panel (fig. 1) loosening them and turn the panel downwards;
- > unscrew the four fastening screws 1 - fig. 1;
- > remove the crankcase pulling it upwards.

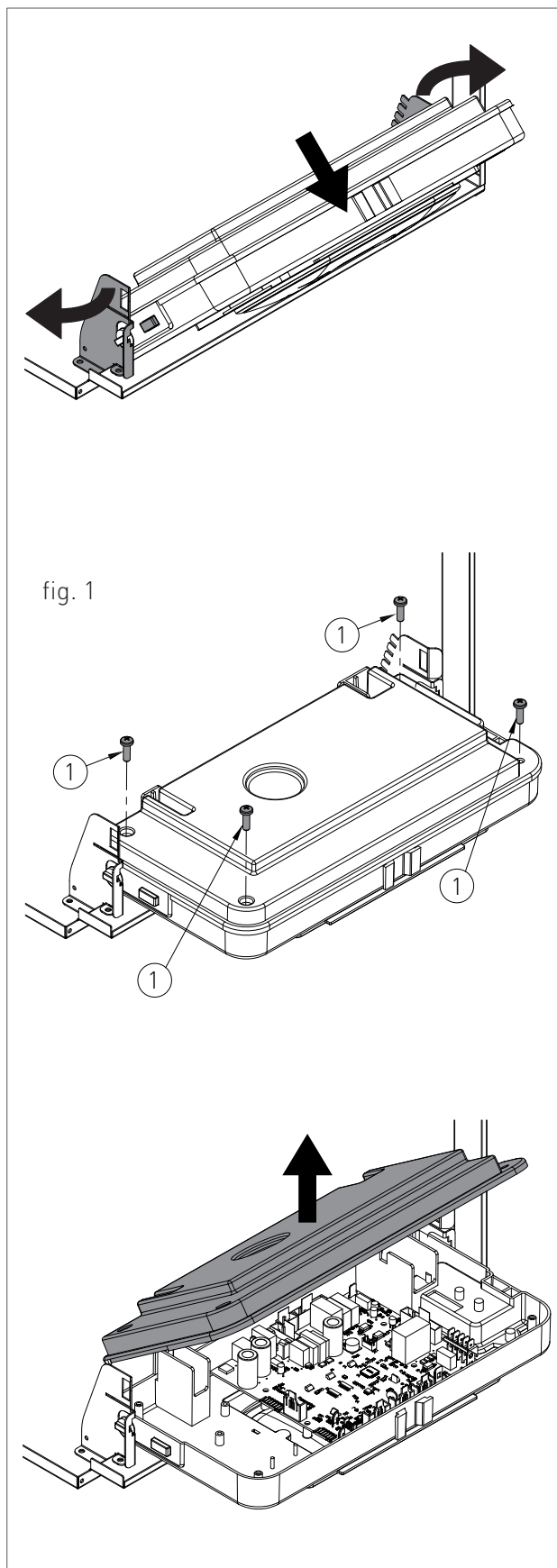









2.2.13. EMPTYING THE DOMESTIC SYSTEM

If there is freezing risk, you have to empty the domestic system as follows:

- > close the main supply tap of the water supply network;
- > open all cold and hot water taps;
- > after completing all operations, close the discharge tap and all previously opened water taps.

2.2.14. FAULT SIGNALLING CODES

To view the last 5 fault signalling codes chronologically, starting with the most recent one, activate the 'OFF' mode by pressing the FUNCTION  key and hold the key INFO  for 5 seconds. Use keys  and  of the symbol recirculation  to scroll through the list of saved faults. To reset the fault history press the RESET  key. To exit display mode press the INFO  key.

CODE	FAULT	POSSIBLE CAUSE	SOLUTION	RESET
E01	FLAME BLOCK	NO FLAME LIGHT UP		MANUAL RESET (PRESS THE RESET  KEY).
		GAS MISSING;	CHECK THE ADDUCTION NETWORK;	
		MASS OR BROKEN START-UP ELECTRODE;	REPLACE IT;	
		GAS VALVE BROKEN;	REPLACE IT;	
		SLOW LIGHT UP TOO LOW ADJUSTMENT;	ADJUST MINIMUM OR SLOW LIGHT UP;	
		VALVE INFEED PRESSURE TOO HIGH (ONLY FOR GPL WATER HEATERS).	CHECK THE MAXIMUM ADJUSTMENT PRESSURE	
		WITH FLAME LIGHT UP		
		NEUTRAL AND PHASE INVERTED POWER SUPPLY;	PROPERLY CONNECT THE POWER SUPPLY;	
		DETECTION ELECTRODE BROKEN;	REPLACE IT;	
		DETECTION ELECTRODE CABLE DISCONNECTED.	CHECK THE WIRING.	
ELECTRICAL CURRENT PHASE-PHASE	IF THE TENSION MEASURES BETWEEN NEUTRAL AND GROUND IS ALMOST EQUAL TO THE ONE MEASURED BETWEEN PHASE AND GROUND, YOU HAVE TO INSTALL A PHASE-PHASE TRANSFORMER KIT (COD. 88021LA)			

2. MAINTENANCE

CODE	FAULT	POSSIBLE CAUSE	SOLUTION	RESET
E02	SAFETY THERMOSTAT	THERMOSTAT CABLE DISCONNECTED;	CHECK THE WIRING;	AUTOMÁTICO.
		BROKEN THERMOSTAT.	REPLACE IT.	
E03	FUMES SAFETY THERMOFUSE (102°C)	THERMOFUSE BROKEN;	REPLACE IT;	MANUAL RESET (PRESS THE RESET  KEY).
		THERMOFUSE CABLE DISCONNECTED.	CHECK THE WIRING.	
E04	D.H.W. INSUFFICIENT PRESSURE	D.H.W. INSUFFICIENT PRESSURE (LOWER THAN 0,3 BAR);	CHECK THE SYSTEM.	AUTOMATIC.
		WATER PRESSURE SWITCH CABLE DISCONNECTED;	CHECK THE WIRING;	
		WATER PRESSURE SWITCH BROKEN.	REPLACE IT.	
E05	INLET PROBE (COLD WATER)	BROKEN OR INCORRECTLY CALIBRATED PROBE (RESISTANCE VALUE 10 KOHM AT 25 °C NTC);	REPLACE IT;	AUTOMATIC.
		DISCONNECTED OR WET PROBE CONNECTOR.	CHECK THE WIRING.	
E06	DOMESTIC CIRCUIT PROBE	BROKEN OR INCORRECTLY CALIBRATED PROBE (RESISTANCE VALUE 10 KOHM AT 25 °C NTC);	REPLACE IT;	AUTOMATIC.
		DISCONNECTED OR WET PROBE CONNECTOR.	CHECK THE WIRING.	
E15	RECIRCULATION MODE PROBE	BROKEN OR INCORRECTLY CALIBRATED PROBE (RESISTANCE VALUE 10 KOHM AT 25 °C NTC);	REPLACE IT;	AUTOMATIC.
		DISCONNECTED OR WET PROBE CONNECTOR.	CHECK THE WIRING.	

2. MAINTENANCE

CODE	FAULT	POSSIBLE CAUSE	SOLUTION	RESET
E16	ELECTRIC FAN	ELECTRIC FAN BOARD BROKEN;	REPLACE IT;	AUTOMATIC.
		ELECTRIC FAN BROKEN;	REPLACE IT;	
		FAULTY POWER SUPPLY CABLE.	REPLACE IT.	
E18	INSUFFICIENT CIRCULATION	EXCHANGER OBSTRUCTED;	CLEAN OR REPLACE THE EXCHANGER;	AUTOMATIC.
		CIRCULATOR BROKEN OR DIRTY IMPELLER.	CLEAN THE IMPELLER OR REPLACE THE CIRCULATOR.	
E21	GENERAL INTERNAL BOARD ERROR	INCORRECT SIGNAL RECOGNITION BY THE MODULATION BOARD MICRO-PROCESSOR.	IF THE MODULATION BOARD DOES NOT RESET THE ERROR AUTOMATICALLY, REPLACE IT.	AUTOMATIC.
E22	PARAMETERS PROGRAMMING REQUEST	MICRO-PROCESSOR MEMORY LOSS.	PARAMETERS REPROGRAMMING.	MANUAL RESET (CUT OFF THE TENSION).
E24	REMOTE INLET PROBE	DISCONNECTED REMOTE INLET PROBE;	SET MANUALLY THE VALUE OF PARAMETER P29 TO '0'.	AUTOMATIC.
		BROKEN OR INCORRECTLY CALIBRATED PROBE (RESISTANCE VALUE 10 KOHM AT 25 °C NTC);	REPLACE IT;	
		DISCONNECTED OR WET PROBE CONNECTOR.	CHECK THE WIRING.	
E26	STORAGE TANK PROBE	BROKEN OR INCORRECTLY CALIBRATED PROBE (RESISTANCE VALUE 10 KOHM AT 25 °C NTC);	REPLACE IT;	AUTOMATIC.
		DISCONNECTED OR WET PROBE CONNECTOR.	CHECK THE WIRING.	

2. MAINTENANCE



CODE	FAULT	POSSIBLE CAUSE	SOLUTION	RESET
E31	SOLAR AUXILIARY BOARD CONNECTION FAULTS (FOR CASCADE WATER HEATERS)	SOLAR AUXILIARY BOARD DISCONNECTED.	SET MANUALLY THE VALUE OF PARAMETER P24 TO '0'.	AUTOMATIC.
		DISCONNECTED SOLAR AUXILIARY BOARD CABLE;	CHECK THE WIRING;	
		FAULTY SOLAR AUXILIARY BOARD;	REPLACE IT;	
		FAULTY MODULATION BOARD;	REPLACE IT;	
E32	COMMUNICATION ERROR BETWEEN THE WATER HEATER BOARD AND THE MODBUS BOARD	NO ELECTRICAL CONNECTION;	CHECK THE WIRING;	AUTOMATIC.
		MODBUS BOARD BROKEN;	REPLACE IT;	
E35	RESIDUAL FLAME	FAULTY DETECTION ELECTRODE;	CLEAN IT OR REPLACE IT;	MANUAL RESET (PRESS THE RESET  KEY).
		FAULTY DETECTION ELECTRODE CABLE;	REPLACE IT;	
		FAULTY MODULATION BOARD.	REPLACE IT.	
E40	SUPPLY VOLTAGE	SUPPLY VOLTAGE OFF THE OPERATION RANGE (≤ 160 VOLTS).	CHECK THE POWER SUPPLY NETWORK (THE ERROR DEACTIVATES AUTOMATICALLY AS SOON AS THE SUPPLY VOLTAGE FALLS BACK WITHIN THE REQUESTED LIMITS).	AUTOMATIC.
E52	COMMUNICATION FAULT BETWEEN MODBUS CONTROLLER AND MODBUS CONTROL UNIT	NO ELECTRICAL CONNECTION;	CHECK THE WIRING;	AUTOMATIC.
		MODBUS CONTROL UNIT BROKEN.	REPLACE IT;	

2. MAINTENANCE

CODE	FAULT	POSSIBLE CAUSE	SOLUTION	RESET
E88	SOLAR AUXILIARY BOARD CONNECTION FAULTS (FOR SOLAR SYSTEM MANAGEMENT WITH SINGLE WATER HEATER)	SOLAR AUXILIARY BOARD DISCONNECTED.	SET MANUALLY THE VALUE OF PARAMETER P30 TO '0'.	AUTOMATIC.
		DISCONNECTED SOLAR AUXILIARY BOARD CABLE;	CHECK THE WIRING;	
		FAULTY SOLAR AUXILIARY BOARD;	REPLACE IT;	
		FAULTY MODULATION BOARD;	REPLACE IT;	

2. MAINTENANCE

2.2.15. ACTIVE FUNCTIONS SIGNALLING CODES

CODE	FUNCTION	DESCRIPTION
F09	D.H.W CIRCUIT ANTI-FREEZE	WHEN THE SANITARY SENSOR DETECTS A TEMPERATURE BELOW 5°C, THE PUMP RUNS AND THE BURNER LIFTS UP THE TEMPERATURE TO 20°C. WHEN THIS LATTER TEMPERATURE IS ACHIEVED, THE BURNER SHUTS OFF AND THE PUMP RUNS FOR 20 SECONDS AS POST CIRCULATION.
F11	SOLAR PANEL FROST PROTECTION	WHEN THE SOLAR PANEL PROBE (OPTIONAL) DETECTS A TEMPERATURE LOWER THAN 4°C, THE SOLAR PUMP IS POWERED, DRAWING HEAT FROM THE LOWER PART OF THE D.H.W. TANK, UNTIL A TEMPERATURE OF 6°C IS REACHED.
F12	SOLAR REMOTE STORAGE TANK FROST PROTECTION	WHEN THE SOLAR LOWER STORAGE TANK PROBE (OPTIONAL) DETECTS A TEMPERATURE LOWER THAN 4°C, THE SOLAR PUMP IS POWERED UNTIL A TEMPERATURE OF 6°C IS REACHED.
F28	ANTI-LEGIONELLA (FOR STORAGE WATER HEATER ONLY)	THE FUNCTION IS ACTIVATED FOR THE FIRST TIME, 60 MINUTES AFTER THAT THE WATER HEATER HAS BEEN ELECTRICALLY POWERED. STARTING FROM THAT MOMENT IT COMES AUTOMATICALLY INTO OPERATION EVERY 7 DAYS, BRINGING THE HOT WATER TEMPERATURE OF THE STORAGE CYLINDER UP TO 60°C. THIS FUNCTION IS ENABLED INDEPENDENTLY FROM THE CONTACT TO THE CYLINDER CLOCK, PROVIDING THAT THE RELATIVE PARAMETER (P15) IS ENABLED.
FH	FAST H2O (FOR INSTANTANEOUS WATER HEATER ONLY)	YOU CAN ACTIVATE/DEACTIVATED IT BY HOLDING SIMULTANEOUSLY AND FOR 7 SECONDS THE RESET  AND  OF THE SYMBOL RECIRCULATION  . THE "FAST H2O" FUNCTION GUARANTEES THE IMMEDIATE D.H.W SUPPLY AT THE REQUESTED TEMPERATURE.

2.2.16. GAS TYPE TRANSFORMATION



ATTENTION

Make sure that the gas adduction tube is suitable for the new type of fuel with which the water heater is supplied.

- › loosen the two screws '1' (fig.1) from the fastening bush, and remove the air suction tube;
- › unscrew the tube coupling that connects the gas valve to venturi;
- › unscrew the three fastening screws '2' (fig.1) of the venturi 'V' (fig.1) using a 10 key, as shown in figure 2;
- › remove the two screws '3' (fig.3) and apply pressure on the rear side of venturi 'C' (fig.3);
- › replace the body venturi with the one suitable for the type of supply gas (cod. 30-00207 for methane / cod. 30-00201 for GPL) and make sure the tooth 'D' (fig.3) is adjusted downwards on the aluminium ring nut (see fig.3);
- › remount the components following the demounting operations in reverse making sure that gasket 'G' is re-assembled as shown in fig.1;
- › set the water heater to operate with the new type of gas, changing the value of the parameter P01 'GAS TYPE SELECTION' from the control panel (see chapters 'DIGITECH CS PARAMETERS TABLE' and 'ACCESSING AND PROGRAMMING THE PARAMETERS');
- › adjust the CO₂ combustion value as indicated in chapter 'CO₂ VALUE CHECK AND CALIBRATION'.

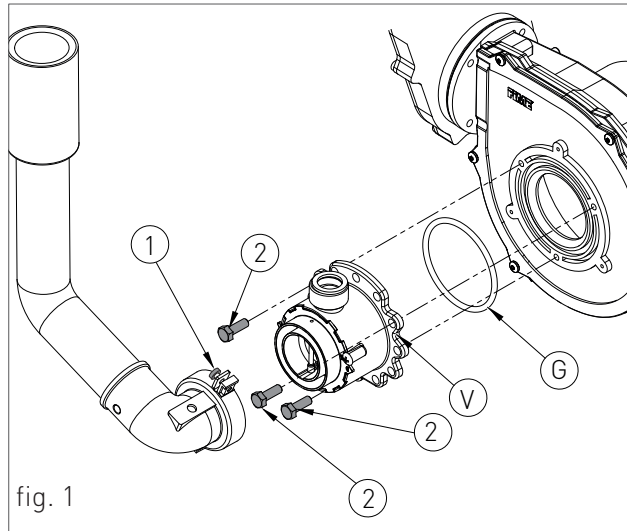

fig. 1

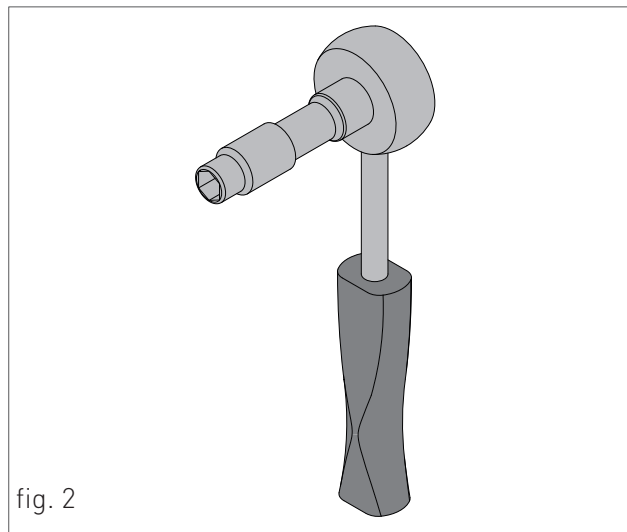

fig. 2

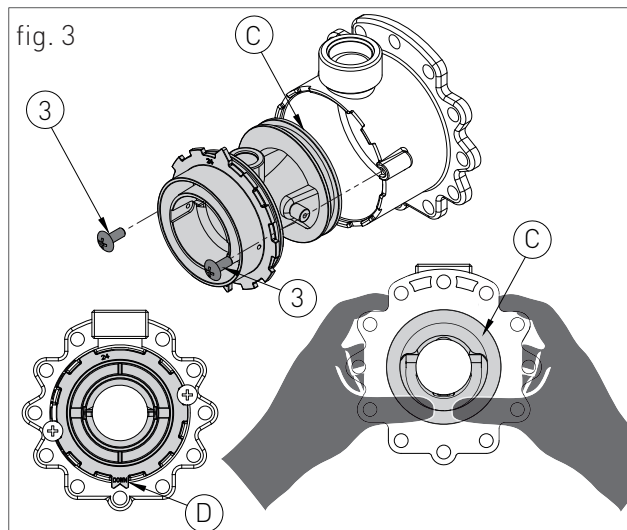

fig. 3

3. USER SECTION

The operations described in this section are addressed to all those who will use the machine. The machine must be used and accessed only by qualified operators that fully read and understood the User section, paying particular attention to the warnings.

3.1. USE

3.1.1. GENERAL USE WARNINGS

**WARNING**

Before starting the water heater the User must make sure that the First start-up certificate has the stamp of the technical Support Centre proving the testing and the first start-up of the water heater .

**WARNING**

In order to take advantage of the guarantee provided by the manufacturer, the customer should carefully and exclusively observe the instructions given in the USER section of the manual.

**ATTENTION**

This machine may be used only for the purpose for which it has been designed: heat water to a temperature below boiling point at atmospheric pressure. Any other use is considered wrong and dangerous. The manufacturer is excluded from any contractual or out of contract responsibility for damage caused to people, animals or property due to incorrect use.

**DANGER**

The water heater should not be used by persons (including children) with reduced physical, sensory or mental capacities or without suitable knowledge or experience unless they are instructed on the device use or monitored by a person responsible for their safety.

**DANGER**

DO NOT obstruct the air vents of the location in which the gas device is installed to prevent the formation of toxic explosive mixes.

**DANGER**

If you sense a gas odour in the location in which the water heater is installed, proceed as follows:

- › DO NOT use electrical switches, the telephone or any other device that might generate electrical discharges or sparks;
- › Immediately open all doors and windows to create an air exchange that can quickly clean the location;
- › Close the gas valves;
- › Request immediate intervention of qualified staff.

**DANGER**

The use of the electrical power water heater implies respecting some fundamental rules such as:

- › DO NOT touch the device with wet and/or humid parts and/or with bare feet;
- › DO NOT pull the electrical cables;
- › DO NOT leave the device exposed to atmospheric agents (rain, sun, etc.) unless specifically intended;
- › in case of cable damage, turn off the device and contact qualified professional staff to replace it.

3.1.2. CONTROL PANEL

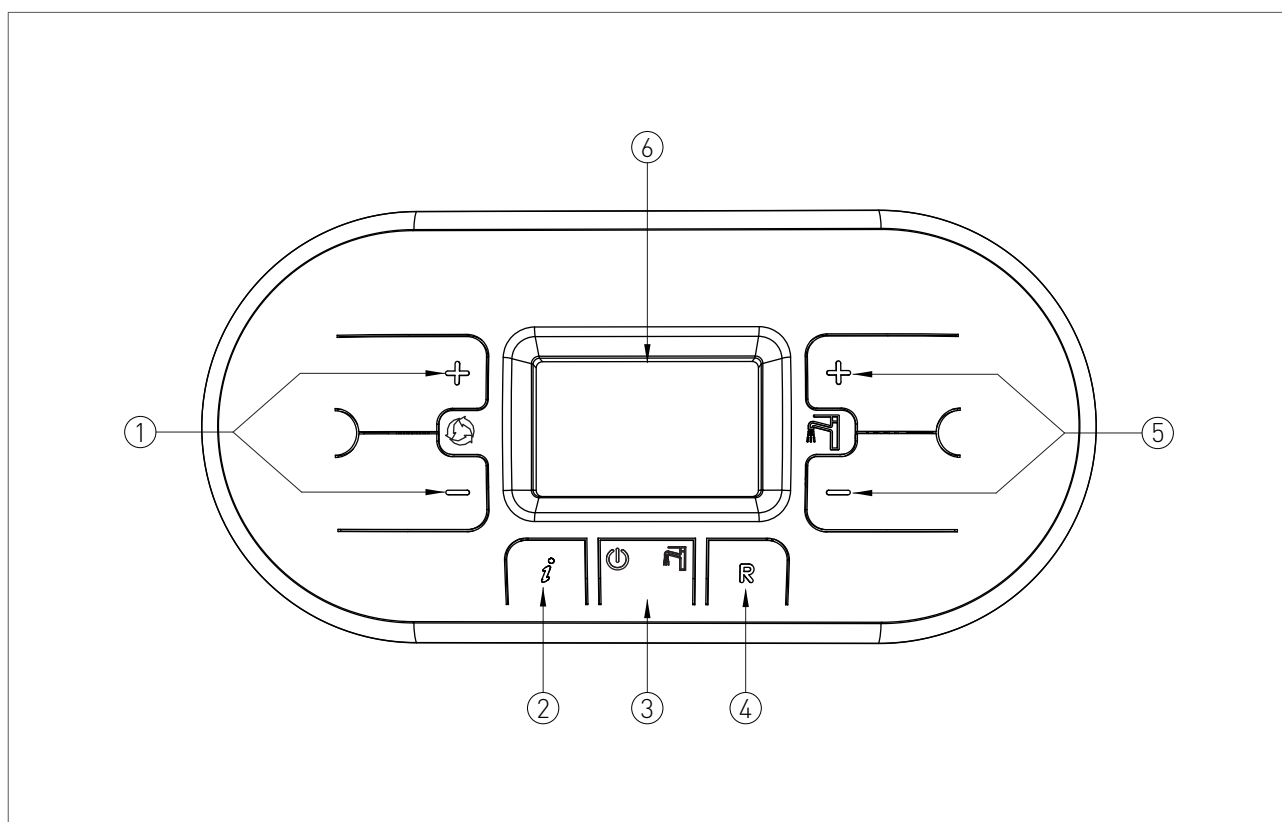

KEY

1. RECIRCULATION MODE TEMPERATURE ADJUSTMENT KEYS
2. INFO KEY: PRESS ONCE TO VIEW THE TEMPERATURES AND OTHER INFORMATION (see chapter 'INFO MENU DISPLAY') - HOLD FOR 5 SECONDS, IN OFF OPERATING MODE, TO VIEW THE LAST 5 FAULTS
3. OPERATING MODE SELECTION KEY: ON/ OFF
4. RESET KEY: FAULTS RESET
5. DOMESTIC HOT WATER TEMPERATURE ADJUSTMENT KEY / HOLD THE KEYS AT THE SAME TIME FOR 5 SECONDS TO ACTIVATE DISPLAY BACK LIGHT FOR 10 MINUTES
6. DISPLAY

3.1.3. DISPLAY ICONS

KEY

1. INDICATION OF PARAMETER NUMBER / DISPLAYED INFO CODE / RECIRCULATION MODE ACTIVE (fig.1)
2. PARAMETERS PROGRAMMING FUNCTION ACTIVE
3. RECIRCULATION PUMP ACTIVE
4. TEMPERATURE DISPLAY / SET POINT / PARAMETER VALUE
5. FLAME PRESENT SIGNALLING / IT ALSO INDICATES, ON 3 PERCENTAGE LEVELS, THE MODULATING POWER LEVEL OF THE WATER HEATER (fig.2)
6. OPERATION IN DOMESTIC MODE ENABLED
7. ERROR DISPLAY THAT CAN BE RESET
8. OFF OPERATING MODE
9. ERROR DISPLAY THAT CAN NOT BE RESET

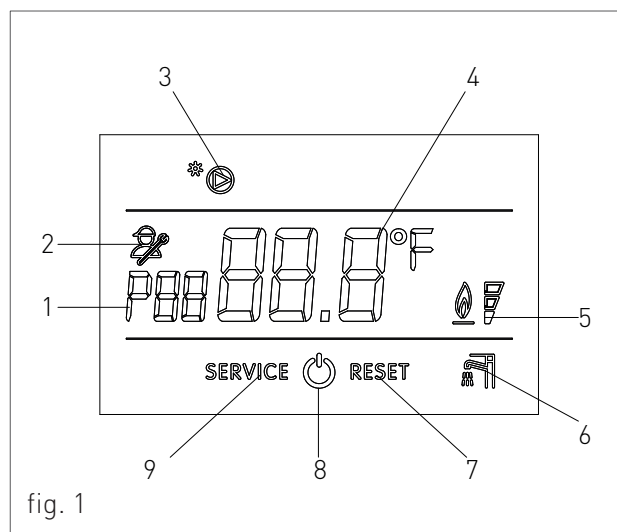

fig. 1

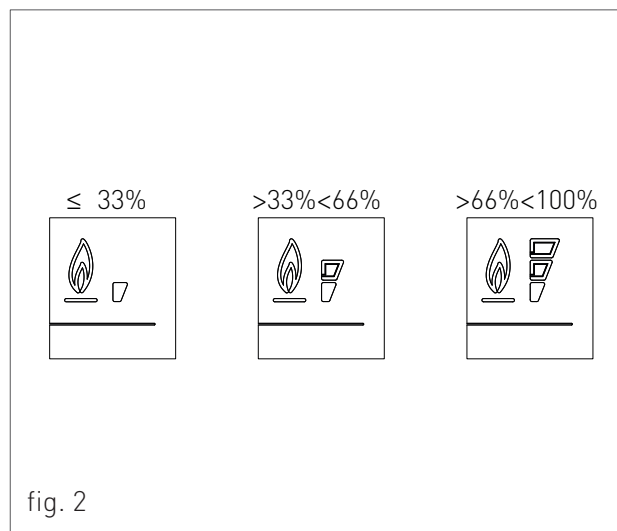







fig. 2

3.1.4. INFO MENU DISPLAY DATA

To view the water heater data from info menu you just have to press the INFO  key. The info code will be displayed on the left side of the screen and its relative value will be displayed on the centre of the screen. Use keys  and  of the symbol recirculation  to scroll through the list of displayed data. To exit display mode press the INFO  key.



LIST OF DISPLAYED DATA

INFO CODE	DESCRIPTION
d0	COLD CIRCUIT INLET PROBE TEMPERATURE
d1	HOT WATER CAPACITY
d2	FAN SPEED
d4	RECIRCULATION PROBE TEMPERATURE
d5	PRIMARY CIRCUIT PROBE TEMPERATURE
d6	SOLAR COLLECTOR PROBE TEMPERATURE (OPZIONAL)
d7	SOLAR BOILER PROBE TEMPERATURE BOTTOM (OPZIONAL)

3.1.5. START-UP

Before starting the water heater make sure that it is powered and that the gas tap below the water heater is open.



To start the water heater press the function key :



To switch the water heater to OFF operating mode, press the function key , the symbol  will appear fixed on the display, indicating that the function is enabled.

If the water heater was previously running, it will be turned off and the post-ventilation and post-circulation functions will be enabled.

3.1.6. OPERATING MODE

DOMESTIC HOT WATER TEMPERATURE ADJUSTMENT



You can adjust the temperature using keys  and  of the domestic circuit :

- press key  to decrease the temperature.
- press key  to increase the temperature.

The hot domestic water temperature adjustment field ranges from 40 °C to 60 °C.

RECIRCULATION MODE TEMPERATURE ADJUSTMENT

You can adjust the temperature using keys  and  of the symbol recirculation :

- press key  to decrease the temperature.
- press key  to increase the temperature.

The return temperature adjustment field ranges from 30 °C to 45 °C.

OFF MODE

In this mode the water heater no longer meets the domestic hot water demands, the anti-freeze and pump anti-locking systems still remain active.

3.1.7. INFORMATIONAL NOTE ON ANTI-FREEZE FUNCTION

The water heater is protected against freezing thanks to the electronic board preparation with functions that start the burner and heat the concerned parts when their temperature goes below the minimum pre-set values.



WARNING

This function is available only if:

- > the water heater is powered;
- > the gas supply is open;
- > the water heater is not blocked.

3.1.8. FAULT SIGNALLING CODES



The water heater might signal some faults by displaying a code. Below you have a list of the codes and of the operations to be performed in order to unlock the water heater.

CODE	ICON	FAULT	INTERVENTION
E01	RESET	FLAME BLOCK	<p>MAKE SURE THAT THE WATER HEATER AND CONTACTOR GAS VALVES ARE OPEN.</p> <hr/> <p>PRESS THE RESET (R) BUTTON ON THE CONTROL PANEL TO RESET THE FAULT, AS SOON AS THE ERROR CODE DISAPPEARS FROM THE DISPLAY, THE WATER HEATER WILL START AUTOMATICALLY.</p> <hr/> <p>IF THE BLOCK PERSISTS CONTACT THE TECHNICAL SUPPORT CENTRE.</p>
E02	RESET	SAFETY THERMOSTAT	CONTACT THE TECHNICAL SUPPORT CENTRE.
E03	RESET	FUMES SAFETY THERMOFUSE (102 °C)	CONTACT THE TECHNICAL SUPPORT CENTRE.
E04	RESET	D.H.W. INSUFFICIENT PRESSURE	CONTACT THE TECHNICAL SUPPORT CENTRE.
E05	SERVICE	INLET PROBE (COLD WATER)	CONTACT THE TECHNICAL SUPPORT CENTRE.
E06	SERVICE	DOMESTIC CIRCUIT PROBE	CONTACT THE TECHNICAL SUPPORT CENTRE.
E15	SERVICE	RECIRCULATION MODE PROBE	CONTACT THE TECHNICAL SUPPORT CENTRE.
E16	SERVICE	ELECTRIC FAN	CONTACT THE TECHNICAL SUPPORT CENTRE.
E18	SERVICE	INSUFFICIENT CIRCULATION	CONTACT THE TECHNICAL SUPPORT CENTRE.
E21	SERVICE	GENERAL INTERNAL BOARD ERROR	<p>CUT OFF THE POWER SUPPLY FROM THE MAIN SWITCH AND THEN RESTORE IT, AS SOON AS THE ERROR CODE DISAPPEARS, THE WATER HEATER WILL RESTART AUTOMATICALLY.</p> <hr/> <p>IF THE BLOCK PERSISTS CONTACT THE TECHNICAL SUPPORT CENTRE.</p>

3. USE

CODE	ICON	FAULT	INTERVENTION
E22	SERVICE	PARAMETERS REQUEST	PROGRAMMING CUT OFF THE POWER SUPPLY FROM THE MAIN SWITCH AND THEN RESTORE IT, AS SOON AS THE ERROR CODE DISAPPEARS, THE WATER HEATER WILL RESTART AUTOMATICALLY. IF THE BLOCK PERSISTS CONTACT THE TECHNICAL SUPPORT CENTRE.
E24	SERVICE	REMOTE INLET PROBE	CONTACT THE TECHNICAL SUPPORT CENTRE.
E26	SERVICE	STORAGE TANK PROBE	CONTACT THE TECHNICAL SUPPORT CENTRE.
E31	SERVICE	SOLAR AUXILIARY BOARD CONNECTION FAULTS (FOR CASCADE WATER HEATERS)	CONTACT THE TECHNICAL SUPPORT CENTRE.
E32	SERVICE	COMMUNICATION ERROR BETWEEN THE WATER HEATER BOARD AND THE MODBUS BOARD	CONTACT THE TECHNICAL SUPPORT CENTRE.
E35	RESET	RESIDUAL FLAME	PRESS THE RESET  BUTTON ON THE CONTROL PANEL TO RESET THE FAULT, AS SOON AS THE ERROR CODE DISAPPEARS FROM THE DISPLAY, THE WATER HEATER WILL START AUTOMATICALLY.
E40	SERVICE	SUPPLY VOLTAGE	CONTACT THE TECHNICAL SUPPORT CENTRE.
E52	SERVICE	COMMUNICATION FAULT BETWEEN MODBUS CONTROLLER AND MODBUS CONTROL UNIT	CONTACT THE TECHNICAL SUPPORT CENTRE.
E88	SERVICE	SOLAR AUXILIARY BOARD CONNECTION FAULTS (FOR SOLAR SYSTEM MANAGEMENT WITH SINGLE WATER HEATER)	CONTACT THE TECHNICAL SUPPORT CENTRE.

3.1.9. ACTIVE FUNCTIONS SIGNALLING CODES

CODE	FUNCTION	INTERVENTION
F09	D.H.W CIRCUIT ANTI-FREEZE FUNCTION ACTIVE	WAIT UNTIL THE OPERATION IS COMPLETED
F11	S O L A R PANEL FROST PROTECTION	WAIT UNTIL THE OPERATION IS COMPLETED
F12	SOLAR REMOTE S T O R A G E TANK FROST PROTECTION	WAIT UNTIL THE OPERATION IS COMPLETED
F28	A N T I - L E G I O N E L L A FUNCTION (FOR STORAGE WATER HEATER ONLY)	WAIT UNTIL THE OPERATION IS COMPLETED
FH	FAST H2O (F O R INSTANTANEOUS WATER HEATER ONLY)	YOU CAN ACTIVATE/ DEACTIVATED IT BY HOLDING SIMULTANEOUSLY AND FOR 7 SECONDS THE RESET  AND  OF THE SYMBOL RECIRCULATION 

- › the hot water is immediately supplied at the requested temperature.
- › unnecessary delays are avoided by increasing the comfort of the final user.
- › water wastes are limited waiting that the water reaches the right temperature.

To activate/deactivate the Fast H2O function please follow the instruction indicated in the paragraph 'ACTIVE FUNCTIONS SIGNALLING CODES'.

3.1.10. FAST H2O FUNCTION

The Fast H2O function keeps a constant temperature in the DHW circuit within the water heater, according to the temperature set by the user.

The Fast H2O function offers three advantages:

3.1.11. MAINTENANCE

To ensure proper water heater safety and efficiency, please check the device every year.

An accurate maintenance should improve system management.

3.1.12. COVER CLEANING

Clean the cover of the device using a wet cloth and come neutral soap.



WARNING

DO NOT use abrasive or powder detergents as they might damage the plastic cover and control elements.

3.1.13. DISPOSAL

The water heater and all its accessories must be differentiated, suitably disposed of in accordance with the standards in force.

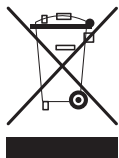

The use of the symbol WEEE (Waste Electrical and Electronic Equipment) shows that this product can not be dismantled as domestic waste. Proper dismantle of this product helps preventing potentially negative consequences on human health and environment.