

# Unvented water heaters

Pioneers, innovators and market leaders in efficient unvented water heating

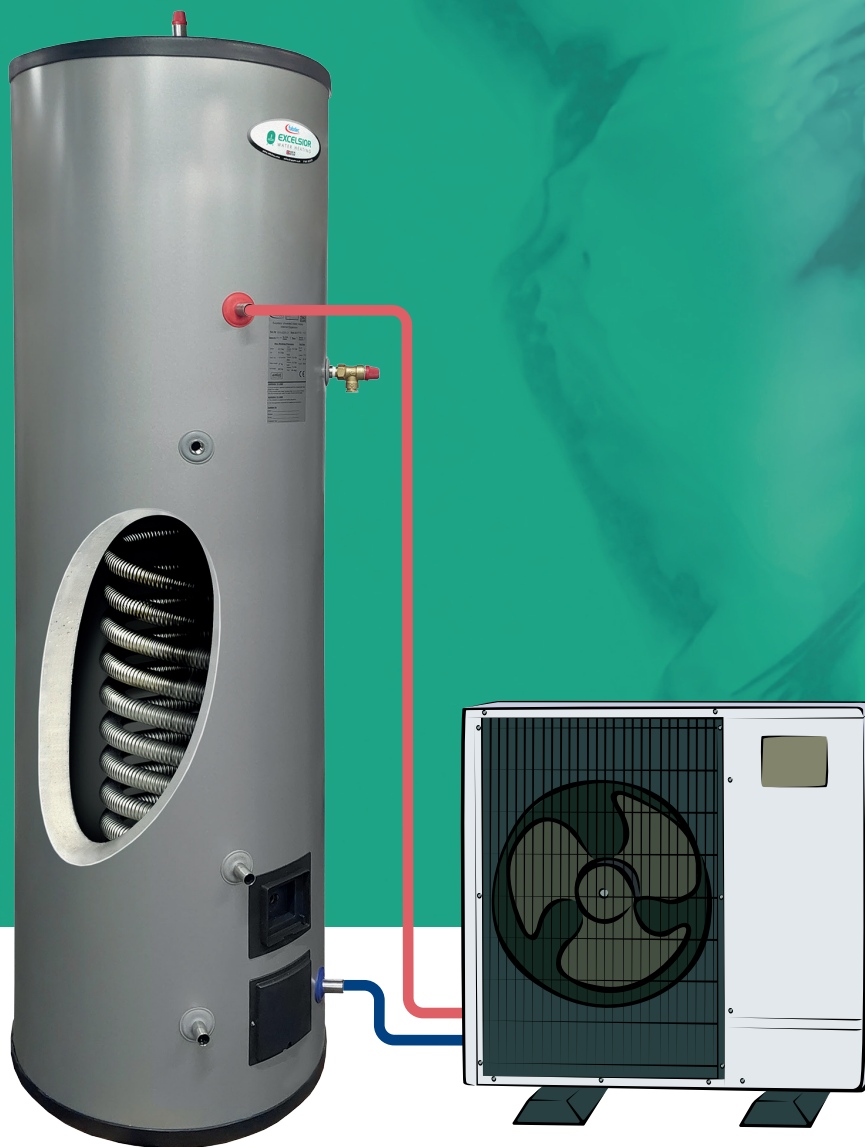

**Designed and manufactured in the UK**



**FLEXIHEAT UK LTD**

[www.flexiheatuk.com](http://www.flexiheatuk.com)

01202 822221

# Excelsior

## Specification guide

### Product construction - typical

<b>Immersion heater</b>	☞ 3kw, 240V, 1ph, Incoloy 825, with thermostat incl. cut-out
<b>Thermal insulation</b>	☞ CFC/HCFC free, (ODP=0, GWP=1), 60mm fire retardant insulation*
<b>Outer casing</b>	☞ P200 Plastisol
<b>Inner cylinder</b>	☞ Duplex stainless steel
<b>Heating coil</b>	☞ High performance, finned
<b>Indirect thermostat</b>	☞ Twin thermostat with independent reset, 30-70°C
<b>Safety device</b>	☞ Factory fitted with 7bar/90°C pressure & temperature relief valve
<b>Connections</b>	☞ Secondary return on 175L & above

\* 50mm on 400L and 500L vessels



### Product specification

<b>Inlet diffuser</b>	☞ For optimal blending of cold & hot water, see fig. 1
<b>Expansion</b>	☞ WXI - 3 bar internal expansion with  <i>All other ranges - 3 bar external expansion</i>
<b>Pressure test</b>	☞ Tested to 10 bar
<b>Secondary return</b>	☞ Standard fit on models 175L & above
<b>Approvals</b>	☞ BBA, CE, WRAS, KIWA, ISO, WRC
<b>Guarantee</b>	☞ Internal cylinder 25 years* Ancillary components 1 year
<b>Direct thermostat</b>	☞ Element thermostat, nominal setting 60°C
<b>Indirect model</b>	☞ 22mm diameter stainless steel high performance coil & outlet with 1 immersion heater
<b>Direct model</b>	☞ 80L fitted with 1 immersion heater; 130 - 500L fitted with 2 immersion heaters
<b>Manufacturing</b>	☞ All UK using state-of-the-art robot technology
<b>Horizontal &amp; Slimline</b>	☞ Suitable for roof voids & 450mmØ specification
<b>Renewables range</b>	☞ Solar, heat pump and buffer vessels

\* Commercial cylinders carry 5 years guarantee

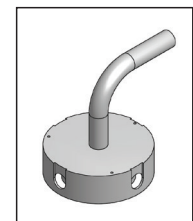



Fig.1

### Features & Benefits

Specifier/buildier features	Installer benefits	Consumer benefits
1 Duplex stainless steel	No sacrificial anode	Low maintenance
2 UK designed & manufactured	Local support	Spares and service back up
3 Butt welded joints	Eliminates corrosion	Long cylinder life
4 Inlet diffuser	Maximises hot water	Maximises hot water
5 High performance heating coil	Fast re-heat times	Constant hot water
6 Minimal heat loss	60mm insulation with outer casing	Lower energy use
7 High flow rates	No shower pumps	Fast filling baths
8 Balanced hot & cold water	Mains pressure to all outlets	High performance showering
9 Pre-plumbed available	Ease of installation	Minimal disruption
10 Twin or triple coil available	Suits all heat sources	Useable with solar or heat pumps
11 Excelsior with 	Reduces installation time	Maintenance-free
12 Hi-Flo Excelsior with 	Suits large domestic/commercial	Higher flow rates with 'Venturi' Technology

# Excelsior

## Heating performance

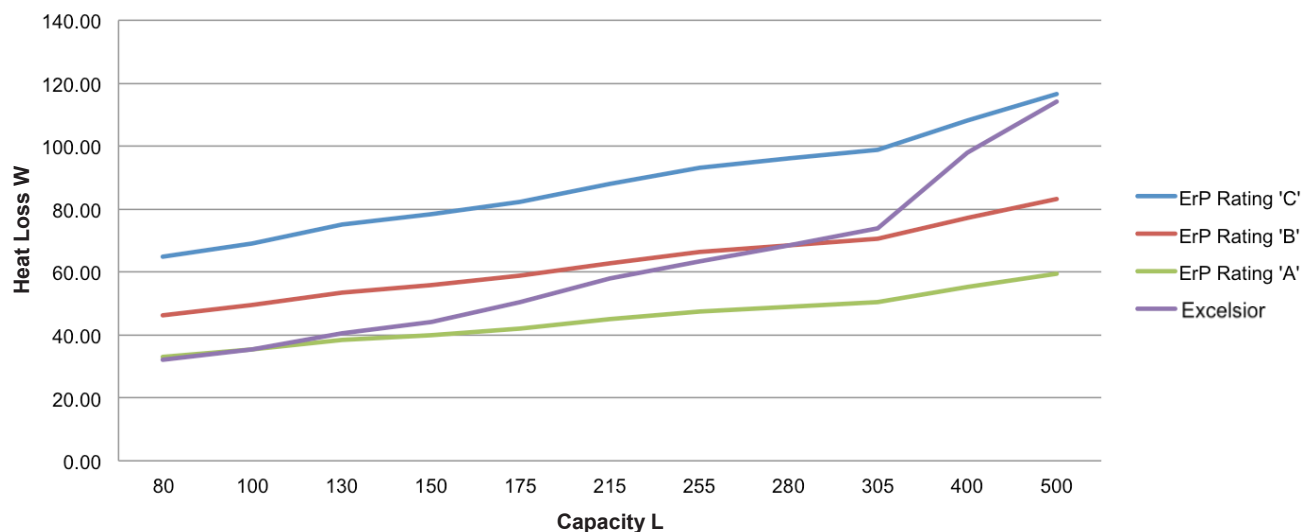

Vessel	Direct			Indirect		Coils (kW)		Weight (kg)		Weight (kg) Full	
	Standing Heat Loss (kW/24h)	Reheat time after 70% draw off*	Time to heat from cold to 65°C*	Reheat time after 70% draw off*	Time to heat from cold to 65°C*	Primary	Direct	Indirect	Direct	Indirect	
80L	0.77	71	102	15	21	14.6	25	30	105	110	
100L	0.85	80	110	17	24	14.6	27	32	127	132	
130L	0.97	83	115	20	27	14.6	30	35	160	165	
150L	1.06	109	123	22	31	14.6	35	40	185	190	
175L	1.21	131	148	21	31	20	40	45	215	220	
215L	1.39	157	182	26	37	20	45	50	260	265	
255L	1.52	191	229	29	42	20	50	55	305	310	
280L	1.64	210	245	32	44	20	53	58	333	338	
305L	1.77	228	261	34	46	20	55	60	360	365	
400L	2.35	220	340	40	57	27	65	68	465	468	
500L	2.74	326	425	55	71	27	75	78	575	578	

\* Time (minutes)

** Vessel	Solar Direct			Solar Indirect		Coils (kW)		Weight (kg)		Weight (kg) Full	
	Standing Heat Loss (kW/24h)	Reheat time after 70% draw off*	Time to heat from cold to 65°C*	Reheat time after 70% draw off*	Time to heat from cold to 65°C*	Aux / Boiler Coil	Primary	Solar Direct	Solar Indirect	Solar Direct	Solar Indirect
130L	-	16	20	-	-	14.6	20	35	40	165	170
150L	-	19	23	-	-	14.6	20	40	45	190	195
175L	-	14	20	14	20	20	27	45	50	220	225
215L	-	17	24	17	24	20	27	50	55	265	270
255L	-	20	29	20	29	20	27	55	60	310	315
305L	-	24	34	24	34	20	27	60	65	365	370

\* Time (minutes)

# Excelsior WXI

Excelsior with  **VENTURI**  
TECHNOLOGY

Current issues with expansion in unvented water heaters:

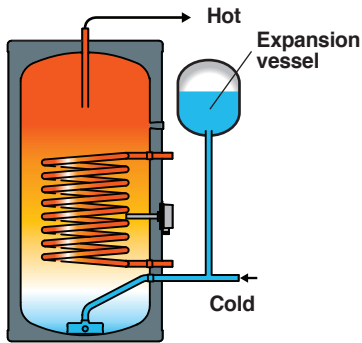

### External expansion

- ✗ Bulky, has more parts, requires more space
- ✗ Requires longer on-site installation
- ✗ Needs replenishment

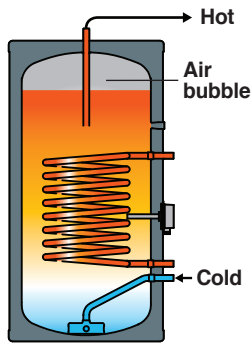

### Internal expansion

- ✗ Integrated air bubble
- ✗ Needs frequent replenishment
- ✗ Takes only low pressure

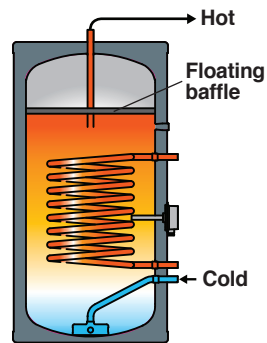

### Protected Internal expansion

- ✗ Integrated air bubble
- ✗ Protected with a plastic baffle
- ✗ Could need replenishment as baffle seal is not fully 100%

## How Venturi technology works:

Water drawn from the mains flows through a patented special inlet device using fluid dynamics to create negative pressure known as the 'Venturi effect'. With precision design this configuration draws enough air to recharge the air gap as the tank is filled and requires minimal ongoing maintenance.

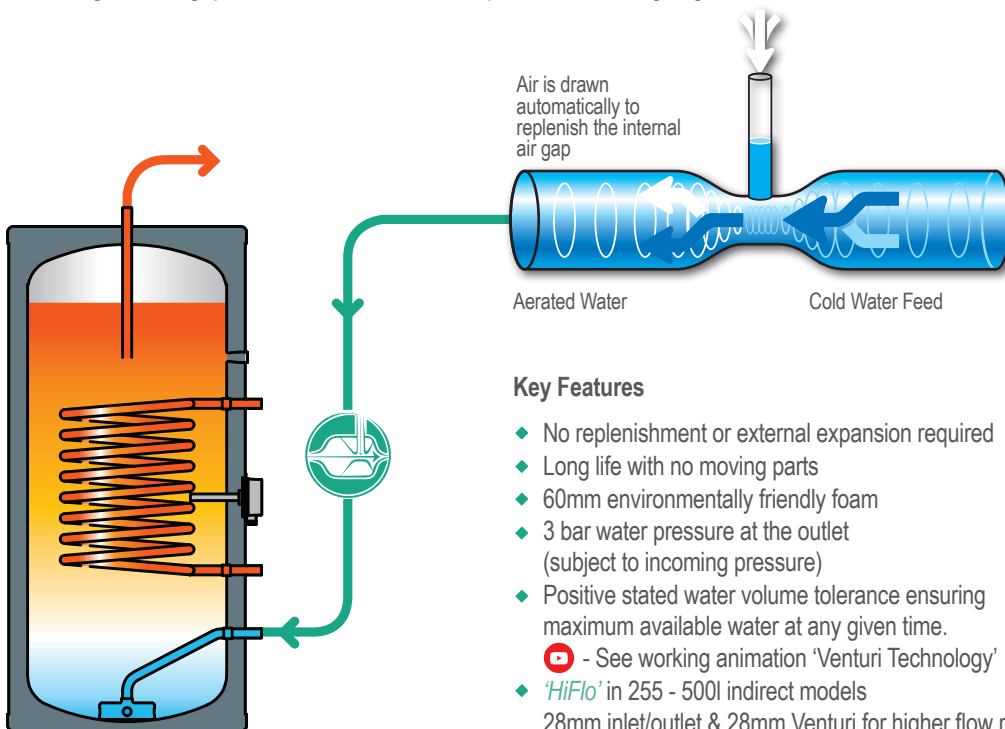

### Key Features

- ◆ No replenishment or external expansion required
- ◆ Long life with no moving parts
- ◆ 60mm environmentally friendly foam
- ◆ 3 bar water pressure at the outlet (subject to incoming pressure)
- ◆ Positive stated water volume tolerance ensuring maximum available water at any given time.
- ◆  - See working animation 'Venturi Technology'
- ◆ 'HiFlo' in 255 - 500l indirect models  
28mm inlet/outlet & 28mm Venturi for higher flow rates

# Excelsior WXI & WXI HiFLO

Excelsior with  **VENTURI**  
TECHNOLOGY

## Direct with internal expansion

Size	H	D	I	O	T	IH1	IH2
80L	703	576	182	*	222	196	-
100L	860	576	182	*	318	196	457
130L	1043	576	182	221	331	196	540
150L	1235	576	182	285	395	196	613
175L	1370	576	182	397	507	196	673
215L	1666	576	182	440	550	196	754
255L	1884	576	182	440	550	196	780
280L	2028	576	182	478	588	196	875
300L	2150	576	182	450	560	196	847
400L	1522	756	220	350	460	235	657
500L	1896	756	220	385	495	235	891

\* Outlet on top of vessel for 80l and 100l models

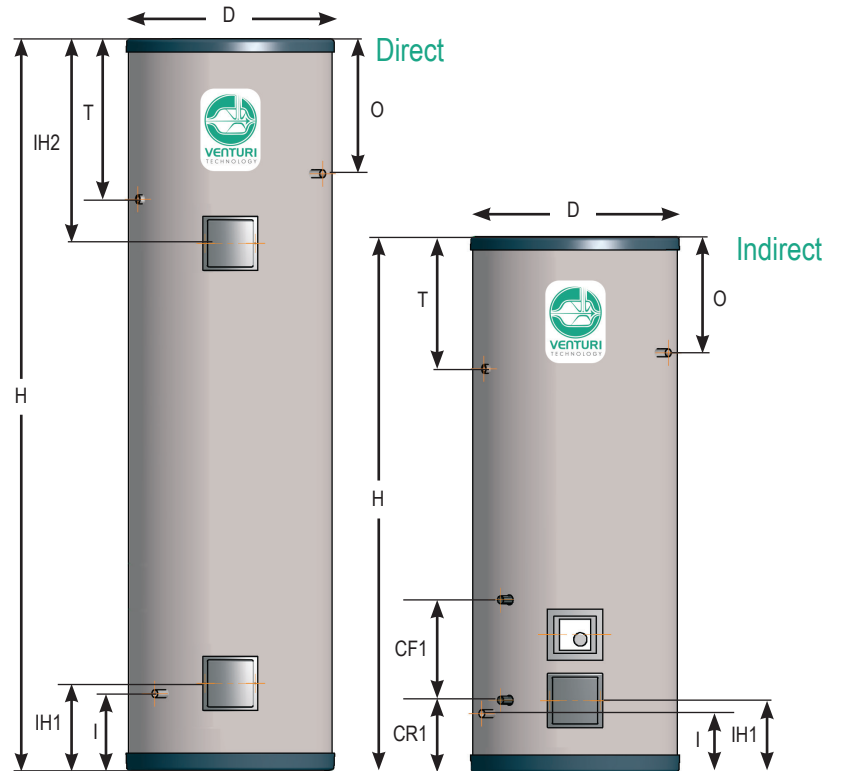

## Indirect with internal expansion

Size	H	D	I	O	T	IH1	CR1	CF1	Coil Rating
80L	703	576	182	*	222	196	213	88	14.6kW
100L	860	576	182	*	318	196	213	88	14.6kW
130L	1043	576	182	221	331	196	213	193	14.6kW
150L	1235	576	182	285	395	196	213	193	14.6kW
175L	1370	576	182	397	507	196	213	263	20.0kW
215L	1666	576	182	440	550	196	213	263	20.0kW
255L	1884	576	182	440	550	196	213	263	20.0kW
280L	2028	576	182	478	588	196	213	263	20.0kW
300L	2150	576	182	450	560	196	213	263	20.0kW
400L	1522	756	220	350	460	235	250	250	27.0kW
500L	1896	756	220	385	495	235	250	250	27.0kW

\* Outlet on top of vessel for 80l and 100l models

## NEW - Indirect with internal expansion with 28mm diameter stainless steel inlet & outlet

Size	H	D	I	O	T	IH1	CR1	CF1	Coil Rating
255L	1884	576	182	440	550	196	213	263	20.0kW
280L	2028	576	182	478	588	196	213	263	20.0kW
300L	2150	576	182	450	560	196	213	263	20.0kW
400L	1522	756	220	350	460	235	250	250	27.0kW
500L	1896	756	220	385	495	235	250	250	27.0kW



# Excelsior WXIS

## Solar range with internal expansion

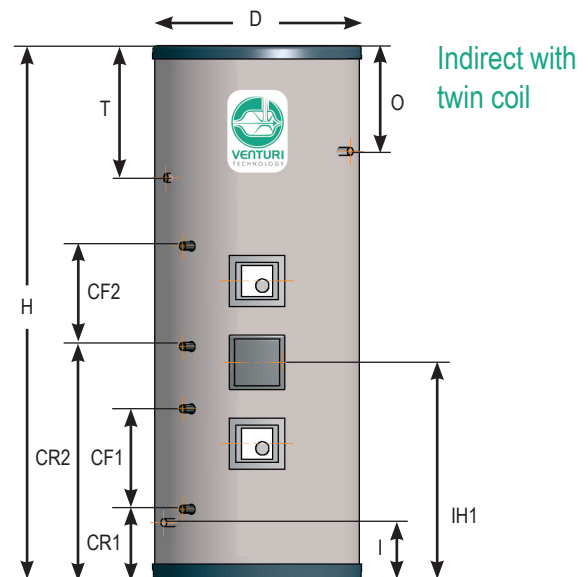
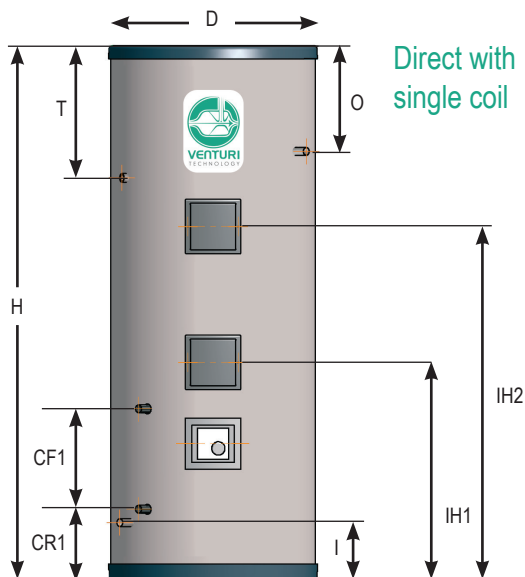

Solar Direct with single coil										Solar Indirect with twin coil		
Size	H	D	I	O	T	IH1	CR1	CF1	Solar Coil Surface Area	CR2	CF2	Aux Coil Surface Area
130L	1043	576	182	221	331	454	212	192	0.75m <sup>2</sup>	504	192	0.54m <sup>2</sup>
150L	1235	576	182	285	395	454	212	192	0.75m <sup>2</sup>	504	192	0.54m <sup>2</sup>
175L	1370	576	182	397	507	580	212	262	1.1m <sup>2</sup>	574	262	0.75m <sup>2</sup>
215L	1666	576	182	440	550	524	212	262	1.1m <sup>2</sup>	574	262	0.75m <sup>2</sup>
255L	1884	576	182	440	550	524	212	262	1.1m <sup>2</sup>	574	262	0.75m <sup>2</sup>
300L	2150	576	182	450	560	524	212	262	1.1m <sup>2</sup>	574	262	0.75m <sup>2</sup>
400L	1522	756	220	350	460	538	250	210	1.1m <sup>2</sup>	560	175	0.75m <sup>2</sup>
500L	1896	756	220	385	495	538	250	210	1.1m <sup>2</sup>	560	175	0.75m <sup>2</sup>

# Excelsior WHPXI

## Heat Pump range with internal expansion

Heat Pump Direct with single coil										Heat Pump Indirect with twin coil			
Size	H	D	I	O	T	IH1	CR1	CF1	Heat Pump Coil Surface Area	CR2	CF2	Coil Surface Areas	
												Lower	Upper
215L	1666	576	182	440	550	284	182	765	2.0m <sup>2</sup>	584	495	1.1m <sup>2</sup>	1.5m <sup>2</sup>
255L	1884	576	182	440	550	284	182	900	2.5m <sup>2</sup>	602	675	1.1m <sup>2</sup>	2.0m <sup>2</sup>
280L	2028	576	182	478	588	284	182	1035	3.0m <sup>2</sup>	652	675	1.1m <sup>2</sup>	2.0m <sup>2</sup>
300L	2150	576	182	450	560	284	182	1035	3.0m <sup>2</sup>	752	675	1.1m <sup>2</sup>	2.0m <sup>2</sup>
400L	1522	756	303	350	460	228	303	495	4.0m <sup>2</sup>	-	-	-	-
500L	1896	756	303	385	495	228	303	495	4.0m <sup>2</sup>	-	-	-	-

# Excelsior WDE

## With external expansion

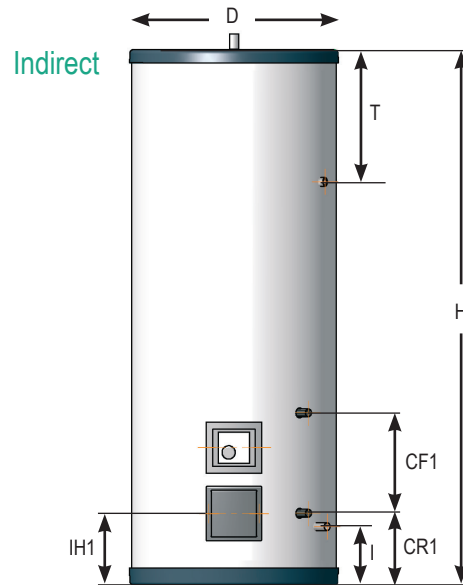
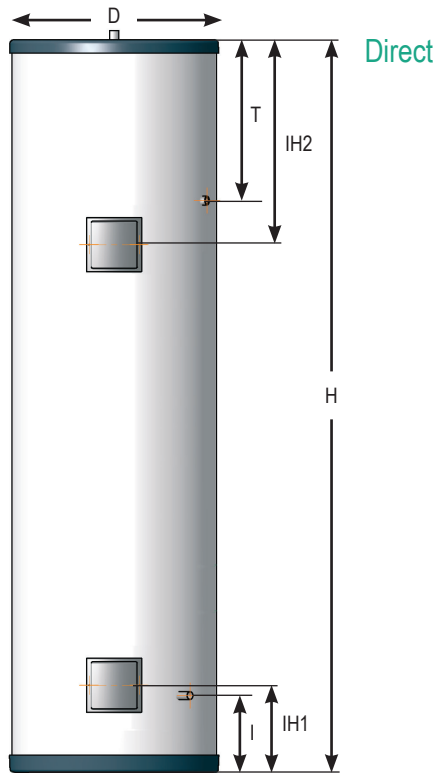

Direct with 3 bar external expansion

Size	H	D	I	T	IH1	IH2
80L	665	576	182	222	196	N/A
130L	957	576	182	222	196	454
150L	1085	576	182	222	196	463
175L	1242	576	182	222	196	545
215L	1484	576	182	222	196	572
255L	1752	576	182	222	196	648
305L	2028	576	182	222	196	725
400L	1405	756	220	262	235	515
500L	1690	756	220	262	235	660

Indirect with 3 bar external expansion

Size	H	D	I	T	IH1	CR1	CF1	Coil Rating
80L	665	576	182	222	196	213	88	14.6kW
130L	957	576	182	222	196	213	193	14.6kW
150L	1085	576	182	222	196	213	193	14.6kW
175L	1242	576	182	222	196	213	263	20.0kW
215L	1484	576	182	222	196	213	263	20.0kW
255L	1752	576	182	222	196	213	263	20.0kW
305L	2028	576	182	222	196	213	263	20.0kW
400L	1405	756	220	262	235	250	245	27.0kW
500L	1690	756	220	262	235	250	245	27.0kW

# Excelsior WS

## Solar range

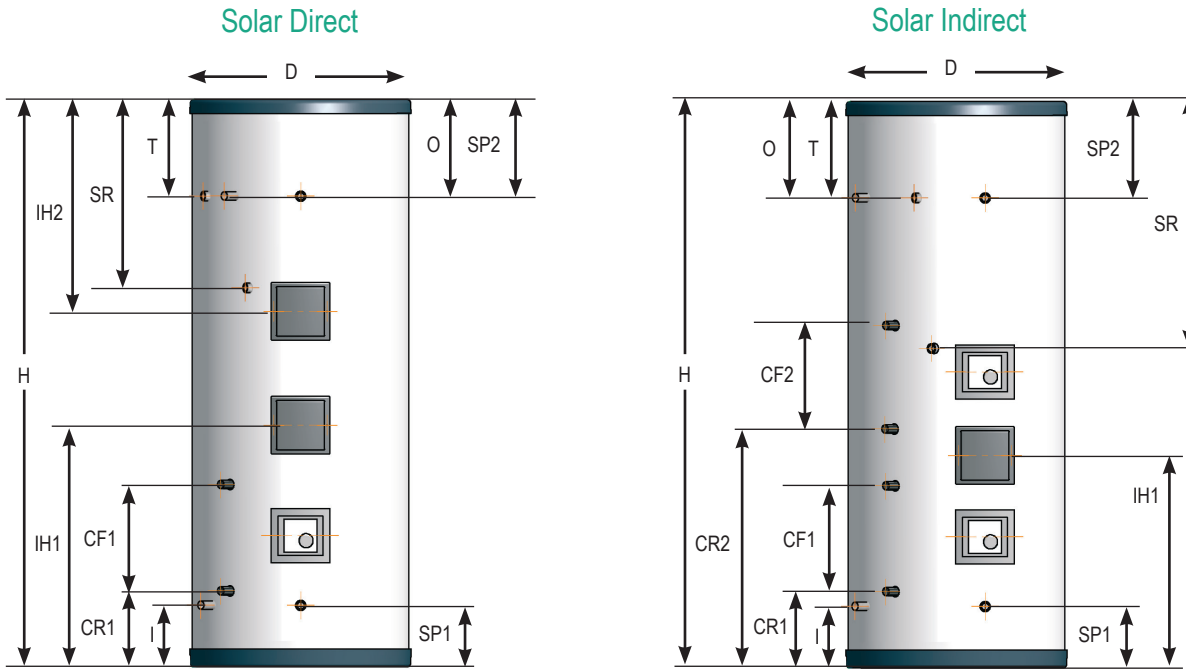

### Solar Direct with external expansion

Size	H	D	I	O	T	CR1	CF1	SP1	IH1	SR	IH2	SP2	Solar Coil Surface Area*	Solar Volume
130L	958	578	183	226	226	213	193	183	454	325	349	226	0.75m <sup>2</sup>	56L
150L	1086	578	183	226	226	213	193	183	509	340	402	226	0.75m <sup>2</sup>	56L
175L	1243	578	183	226	226	213	267	183	584	473	402	226	1.1m <sup>2</sup>	69L
215L	1485	578	183	226	226	213	267	183	587	665	476	226	1.1m <sup>2</sup>	69L
255L	1753	578	183	226	226	213	267	183	587	665	476	226	1.1m <sup>2</sup>	69L
305L	2029	578	183	226	226	213	267	183	587	665	476	226	1.1m <sup>2</sup>	69L
400L	1405	755	220	260	260	250	210	220	538	615	425	260	1.1m <sup>2</sup>	69L
500L	1690	755	220	260	260	250	210	220	538	615	425	260	1.1m <sup>2</sup>	69L

### Solar Indirect with external expansion

Size	H	D	I	O	T	CR1	CF1	SP1	CR2	CF2	IH1	SR	SP2	Solar Coil Surface Area*	Aux Coil Surface Area*	Aux Coil Rating	Solar Volume
130L	958	578	183	226	226	213	193	183	504	193	454	325	226	0.75m <sup>2</sup>	0.54m <sup>2</sup>	14.6kW	56L
150L	1086	578	183	226	226	213	193	183	504	193	454	340	226	0.75m <sup>2</sup>	0.54m <sup>2</sup>	14.6kW	56L
175L	1243	578	183	226	226	213	267	183	578	263	530	473	226	1.1m <sup>2</sup>	0.75m <sup>2</sup>	20.0kW	69L
215L	1485	578	183	226	226	213	267	183	582	263	530	591	226	1.1m <sup>2</sup>	0.75m <sup>2</sup>	20.0kW	69L
255L	1753	578	183	226	226	213	267	183	582	263	530	665	226	1.1m <sup>2</sup>	0.75m <sup>2</sup>	20.0kW	69L
305L	2029	578	183	226	226	213	267	183	582	263	530	665	226	1.1m <sup>2</sup>	0.75m <sup>2</sup>	20.0kW	69L
400L	1405	755	220	260	260	250	210	220	560	175	510	470	260	1.1m <sup>2</sup>	0.75m <sup>2</sup>	20.0kW	69L
500L	1690	755	220	260	260	250	210	220	560	175	510	543	260	1.1m <sup>2</sup>	0.75m <sup>2</sup>	20.0kW	69L



# Excelsior WT

## Slimline Direct / Indirect range

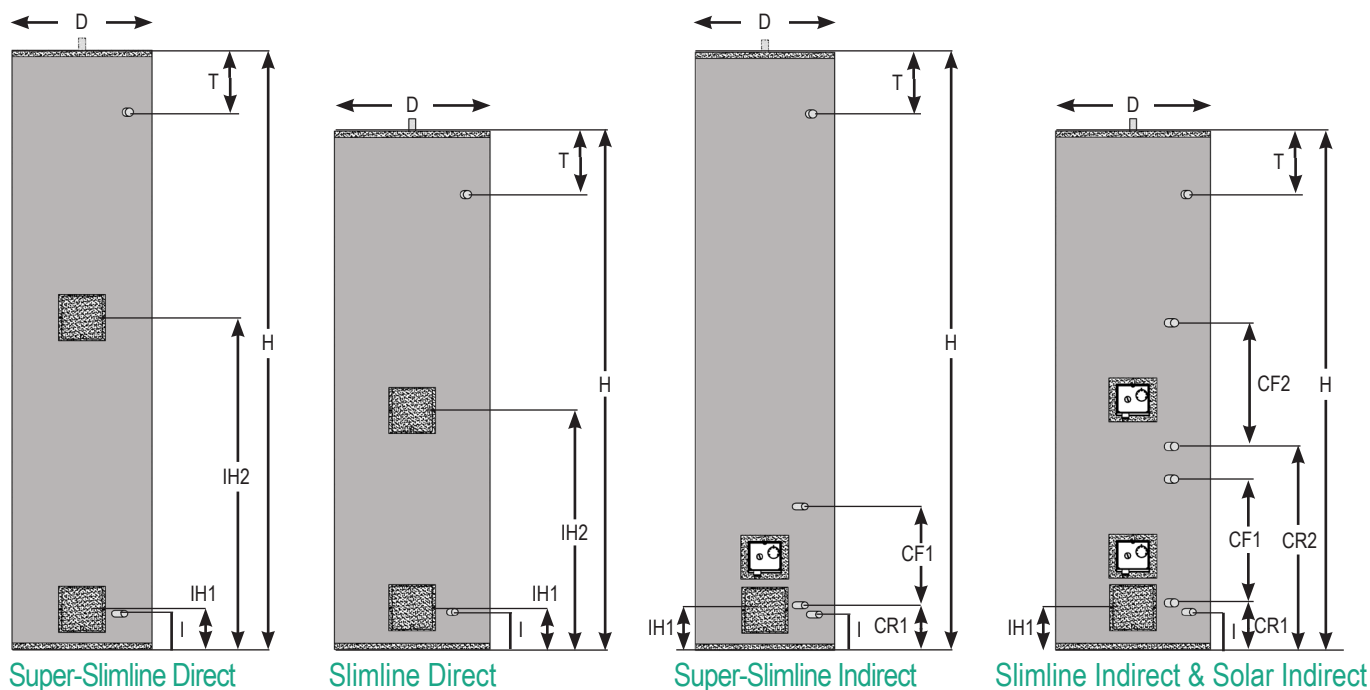

Slimline Direct with external expansion							Slimline Indirect with external expansion								
Size	H	D	I	T	IH1	IH2	Size	H	D	I	T	IH1	CR1	CF1	Coil Rating
100L	1044	515	179	207	193	550	100L	1044	515	179	207	193	209	320	14.6kW
130L	1326	515	179	207	193	643	130L	1326	515	179	207	193	209	320	14.6kW
150L	1466	515	179	207	193	682	150L	1466	515	179	207	193	209	320	14.6kW
175L	1738	515	179	207	193	832	175L	1738	515	179	207	193	209	400	20.0kW
210L	2010	515	179	207	193	1008	210L	2010	515	179	207	193	209	400	20.0kW

**Now available - Slimline Solar Indirect with external expansion**

Size	H	D	I	T	IH1	CR1	CF1	CR2	CF2	Solar Coil Surface Area*	Aux Coil Surface Area*	Aux Coil Rating
130L	1326	515	179	207	504	209	245	554	245	0.75m <sup>2</sup>	0.54m <sup>2</sup>	14.6kW
150L	1466	515	179	207	504	209	245	554	245	0.75m <sup>2</sup>	0.54m <sup>2</sup>	14.6kW
175L	1738	515	179	207	609	209	350	659	315	1.1m <sup>2</sup>	0.75m <sup>2</sup>	20.0kW
210L	2010	515	179	207	609	209	350	659	315	1.1m <sup>2</sup>	0.75m <sup>2</sup>	20.0kW

Super-Slimline Direct with external expansion							Super-Slimline Indirect with external expansion								
Size	H	D	I	T	IH1	IH2	Size	H	D	I	T	IH1	CR1	CF1	Coil Rating
80L	1110	462	165	200	179	-	80L	1110	462	165	200	179	195	320	14.6kW
100L	1344	462	165	200	179	664	100L	1344	462	165	200	179	195	320	14.6kW
130L	1716	462	165	200	179	850	130L	1716	462	165	200	179	195	320	14.6kW
150L	1935	462	165	200	179	1122	150L	1935	462	165	200	179	195	320	14.6kW
165L	1998	462	165	200	179	1221	165L	1998	462	165	200	179	195	400	20.0kW

# Excelsior WZ

## Horizontal vessels



### Horizontal Direct

Size	A
130L	957
150L	1085
175L	1242
215L	1484
255L	1752
305L	2028

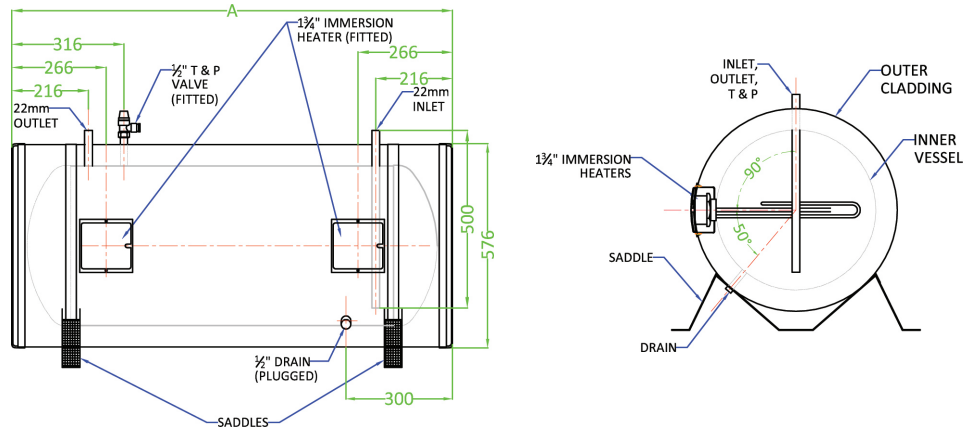

### Horizontal Indirect

Size	A	B	C	Aux Coil m <sup>2</sup>
130L	957	478	298	0.54
150L	1085	543	363	0.54
175L	1242	621	371	0.75
215L	1484	742	492	0.75
255L	1752	876	626	0.75
305L	2028	1014	769	0.75

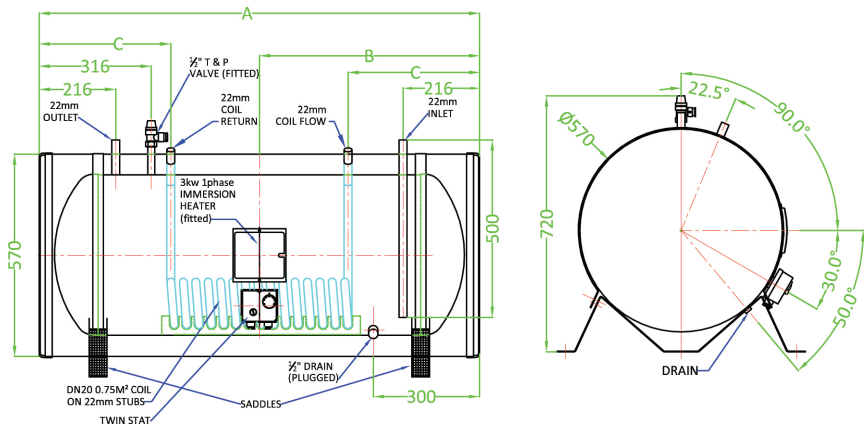

# Excelsior WHP

## Heat Pump range with external expansion

### Heat Pump Single Coil

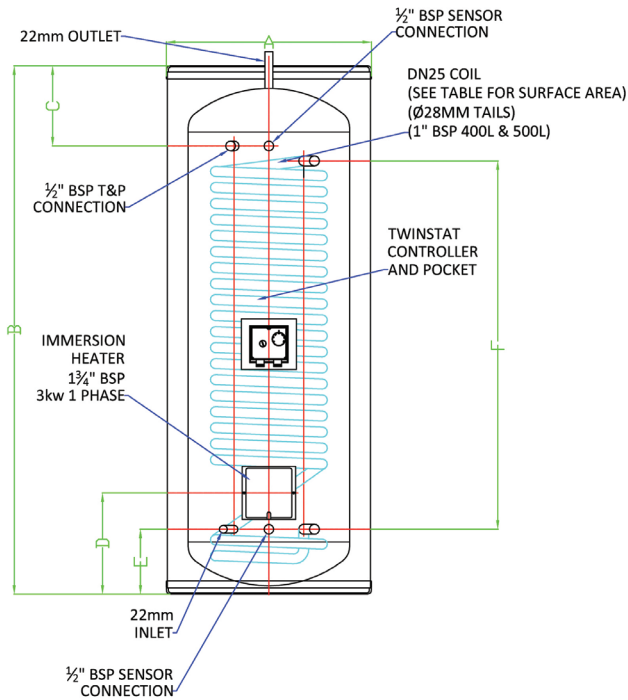

### Heat Pump Twin Coil

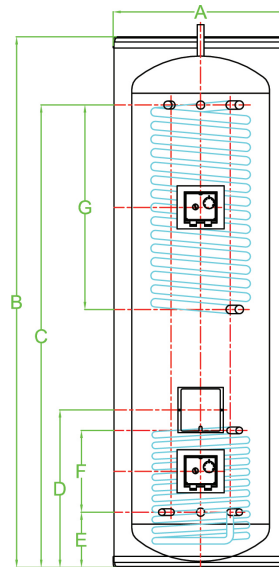

### Heat Pump single coil with external expansion

Size	A	B	C	D	E	F	HP Coil Surface Area*
150L	575	1085	225	284	182	678	2m <sup>2</sup>
175L	575	1242	225	284	182	720	2m <sup>2</sup>
215L	575	1485	225	284	182	1035	3m <sup>2</sup>
255L	575	1752	225	284	182	1035	3m <sup>2</sup>
275L	575	1884	225	284	182	1035	3m <sup>2</sup>
305L	575	2028	225	284	182	1035	3m <sup>2</sup>
400L	750	1405	262	303	228	495	4m <sup>2</sup>
500L	750	1690	262	303	228	495	4m <sup>2</sup>

### Heat Pump twin coil with external expansion

Size	A	B	C	D	E	F	G	HP Coil Surface Area*	Solar Coil Surface Area
150L	575	1085	856	355	182	105	385	1.5m <sup>2</sup>	0.54m <sup>2</sup>
175L	575	1242	1013	460	182	210	525	1.5m <sup>2</sup>	0.75m <sup>2</sup>
215L	575	1485	1259	520	182	270	675	2m <sup>2</sup>	1.1m <sup>2</sup>
255L	575	1752	1527	520	182	270	675	2m <sup>2</sup>	1.1m <sup>2</sup>
-	-	-	-	-	-	-	-	-	-
305L	575	2028	1800	520	182	270	675	2m <sup>2</sup>	1.1m <sup>2</sup>
400L	750	1430	1196	655	276	315	480	3m <sup>2</sup>	2m <sup>2</sup>
500L	750	1715	1481	655	276	315	720	4m <sup>2</sup>	2m <sup>2</sup>

Standard coil inlet and outlet diameter 28mm (DN25); Other coil sizes available upon request.

### NEW - with 28mm inlet & outlet - single coil

Size	A	B	C	D	E	F	HP Coil Surface Area*
400L	750	1405	262	228	228	495	4m <sup>2</sup>
500L	750	1690	262	228	228	495	4m <sup>2</sup>

### NEW - with 28mm inlet & outlet - twin coil

Size	A	B	C	D	E	F	G	HP Coil Surface Area*	Solar Coil Surface Area
400L	750	1430	1196	655	276	315	480	3m <sup>2</sup>	2m <sup>2</sup>
500L	750	1715	1481	655	276	315	720	4m <sup>2</sup>	2m <sup>2</sup>

Standard coil inlet and outlet diameter 28mm (DN25); Other coil sizes available upon request.