



FLEXIHEAT UK LTD
www.flexiheatuk.com
01202 822221



LEO HD

Air heating and ventilation
in special purpose buildings

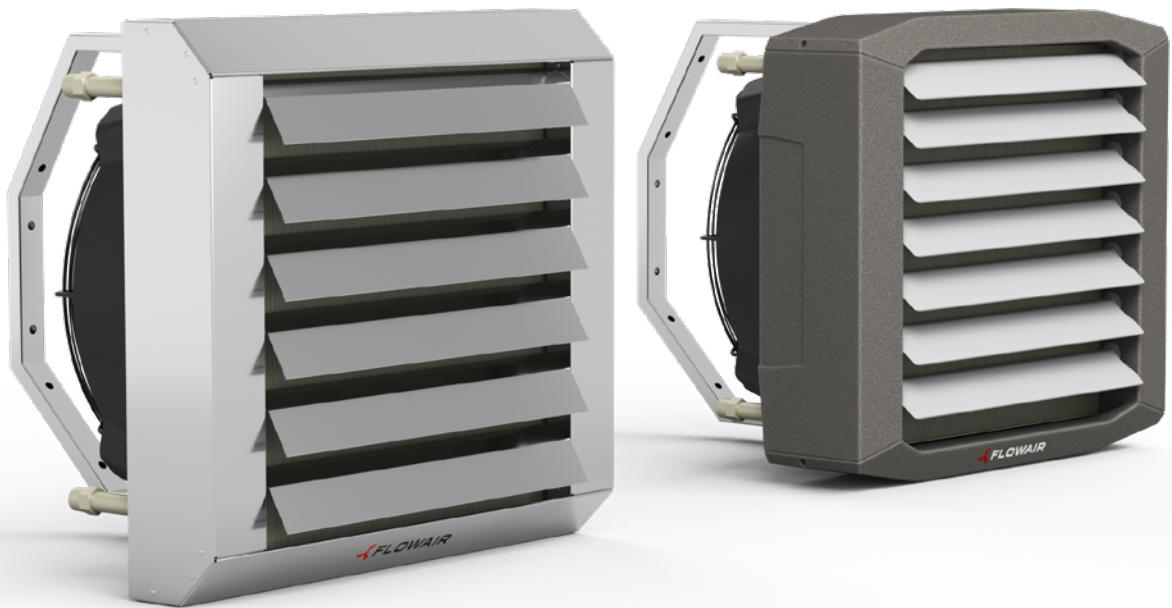

Water fan heaters

**Air flow**

up to 3,800 m³/h

**Heating capacity**

up to 38.4 kW

**Weight**

11.3 - 25.3 kg

**Corrosion class**

C5-h according to
12944-6:2018

What is LEO HD?

The LEO HD fan heater is designed for building structures that require equipment with increased resistance to environmental conditions. The water heat exchanger installed in the heater is covered with special pigmented polyurethane coating PoluAl XT Blygold, which is characterised by very high resistance to corrosion and chemical compounds.

Types of units

- LEO HD AC IP54 - fan heater with AC fan
- LEO HD EC IP54 - fan heater with EC fan
- LEO HD AC IP66 - fan heater with AC fan with higher protection level IP66

All available models can be manufactured in one of two types of casings: expanded polypropylene (EPP) or stainless steel INOX AISI316L.



Application

- washing facilities
- wastewater treatment plants
- galvanizing plants
- food industry buildings
- greenhouses
- chemical industry
- maritime industry

Types of unit



A full series of LEO HD fan heaters means that you can choose the ideal solution for the needs of your building. FLOWAIR offers fan heater models with a wide range of heating capacity, whose parameters have been confirmed by an independent testing laboratory.

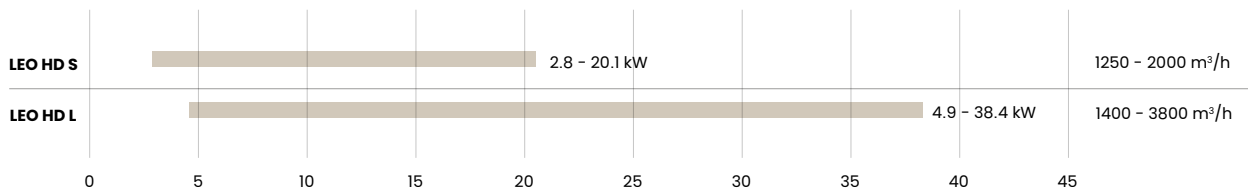

Heating power range specified at the following parameters:
min. – 1st fan speed, heating medium temperature 40/30°C, air temperature at unit inlet 20°C;
max. – 3rd fan speed, heating medium temperature 90/70°C, air temperature at device inlet 0°C.

As many as 10 fan heater models, in 2 casing versions! INOX console included! Match the device to the building's requirements even better

INOX – casing made of acid-resistant steel AISI316L. Standard design.

EPP – expanded polypropylene casing. Standard design.



BLYGOLD heat exchanger

Standard heat exchangers are vulnerable to intense corrosion due to the nature of their design, which often involves different metals with incompatible chemical properties. The combination of these metals can cause galvanic corrosion, especially when they are exposed to moisture and other substances. In addition, heat exchangers are often placed in environments featuring contaminated air, which can accelerate the corrosion process through chemical reactions.

The **Blygold coating**, as used in LEO HD, is an effective solution that provides lasting corrosion protection for heat exchangers, while maintaining heat transfer efficiency and minimal impact on pressure drop.



Design of LEO HD

Thanks to its clever design and the Blygold coating used on the exchangers, the LEO HD device is ideal for special purpose buildings.

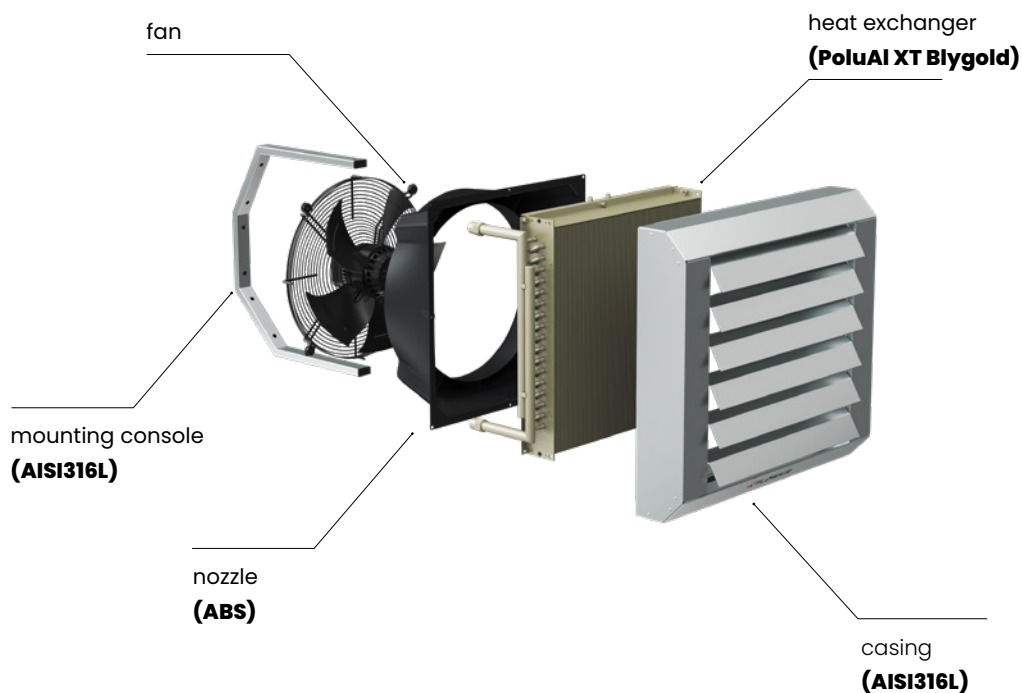







Table of PoluAl XT coating resistance

Name	Max. concentration [ppm]	Other
Inorganic acids		
Arsenic acid		Carbon disulphide 160
Boric acid	641	Hydrogen peroxide 320
Hydrogen carbonate		Hydrogen sulphide 20
Chromic acid		Chlorine 64
Sulphonic acid		
Bromic acid		Organic acids
Hydrochloric acid		Acetic acid
Hydrogen fluoride		Benzoic acid
Hydrogen sulphide	320	Lactic acid
Nitric acid		Phenols
Sulphuric acid		Citric acid
Phosphoric acid		Fatty acids
Perchloric acid		Stearic acid
Selenic acid		Hydrocyanic acid
		Malic acid
		Margaric acid 320
		Picric acid
Bases		Oleic acid
Ammonia 160		Oxalic acid
Sodium hydroxyde		Sulphamic acid
Potassium hydroxide solution		Palmitic acid
Lithium hydroxide 20		Tannin
Calcium hydroxide		Phthalic acid
Magnesium hydroxide		Valerian acid
		Salicylic acid
Alts and aqueous solutions		Formic acid 80
Sodium salt		Propionic acid
Potassium salts		
Calcium salt		Ketones and aldehydes
Aluminium salts		Acetone
Ammonium salts		Acetaldehyde
Barium salts		Benzaldehyde
Copper salts 640		Formaldehyde
Lead salts		Salicylaldehyde 320
Lithium salts		Diisobutyl ketone
Magnesium salts		Methylethylketone
Mercury salts		Butanal
Lithopone		Crotonaldehyde
Hydroquinone		
Iron salts		Alcohols
		Methanol
Aromatic hydrocarbons		Ethanol
Xylene		Isopropanol
Toluene		n-Butanol
Bitumen		Amyl alcohol 320
Anthracene		Benzyl alcohol
Benzaferen 640		Diacetone alcohol DAA
Benzene		Glycerol
Solvent naphtha		n- Propanol
Naphthalene		Pentanol
Terpenes		



Technical data, accessories and installation of units

	LEO HD S AC	LEO HD S EC	LEO HD L AC	LEO HD L AC IP66	LEO HD L EC
Step (AC) / Voltage setting [V] (EC)	3 2 1	10 8 6 4	3 2 1	5 4 3 2 1	10 8 6 4
Air flow [m ³ /h]*	2000 1600 1250	1650 1300 950 600	3800 2400 1400	3800 3500 2930 2300 1400	3000 2750 2850 950
Current consumption [A]	0,6 0,4 0,3	0,55 0,31 0,15 0,1	1,5 1,2 0,6	1,7 1,4 1,2 1,1 0,8	1,3 0,8 0,4 0,2
Power consumption [W]	130 90 70	60 41 22 10	340 240 120	355 293 259 214 158	170 113 56 21
Heating capacity (70 / 50 / 15°C) [kW]	11,8 10,4 9	10,4 9,2 7,6 5,6	20,8 15,8 11,1	20,8 19,8 17,9 15,4 11,1	1,3 0,8 0,38 0,14
Acoustic pressure level ⁽²⁾ [dB(A)]	54,4 48,8 42	54 46,8 40,7 32,1	62,3 52,6 40,2	62,3 61,3 57,5 52,3 40,2	56 53,1 45,7 36,2
Acoustic power level ⁽³⁾ [dB(A)]	71,4 65,8 59	71 63,8 57,7 49,1	79,2 69,6 57,2	79,2 78,3 74,5 69,3 57,2	73 70,1 62,7 53,2
Max. outlet temperature [°C]	31	37,5	38,5	38,5	41
Max. horizontal isothermal range ⁽⁴⁾ [m]	27	22,5	41	41	33
Max. operating pressure [MPa]	1,6	1,6	1,6	1,6	1,6
Max. heating medium temperature [°C]	120	120	120	120	120
Operating temperature range [°C]	-30 to 60	-30 to 60	-30 to 60	-30 to 60	-30 to 60
Fan type / protection level	AC / IP54	EC / IP54	AC / IP54	AC / IP66	EC / IP54
Rated voltage [V / Hz]	230 / 50	230 / 50	230 / 50	230 / 50	230 / 50
Water connection ["]	½	½	¾	¾	¾
Maximum capacity ⁽⁵⁾ [m ² / h]	2000	1650	3800	3800	3000
Casing type	EPP / INOX	EPP / INOX	EPP / INOX	EPP / INOX	EPP / INOX
Weight [kg]	12,4 / 17,2	11,3 / 16,1	18,5 / 24,2	19,4 / 25,3	16,6 / 22,5
Unit weight filled with water [kg]	13,6 / 18,4	12,5 - 17,3	20,5 / 26,4	21,4 / 27,3	18,6 / 24,5
Compatible with heat pump					

⁽¹⁾ Air flow measured in accordance with EN ISO 5801

⁽²⁾ Acoustic pressure level for a room with average sound absorption, volume 3000m³, at a distance of 5m from the unit

⁽³⁾ Acoustic power level in accordance with EN ISO 3744:2011

⁽⁴⁾ Horizontal isothermal range for ΔT = 5°C and for 0,3 m/s border air stream speed

⁽⁵⁾ Vertical nonisothermal range for ΔT = 5°C and for 0,3 m/s border air stream speed

Dimensions

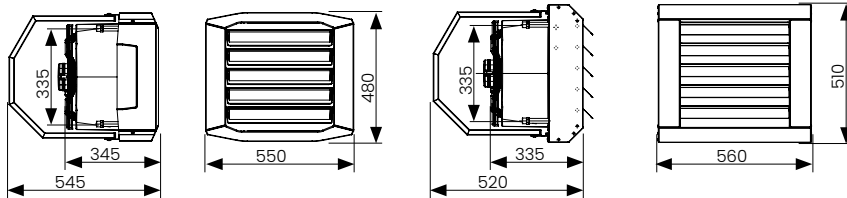

LEO HD S EPP

LEO HD S INOX

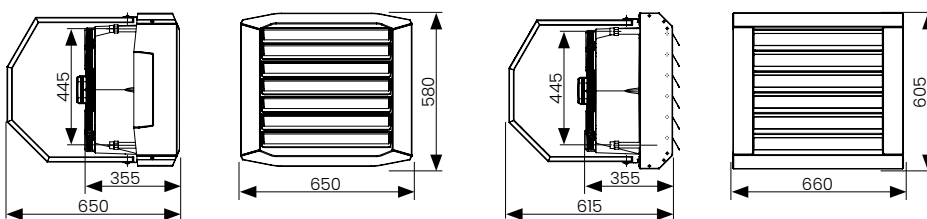

LEO HD L EPP

LEO HD L INOX

Installation of the LEO HD fan water heater

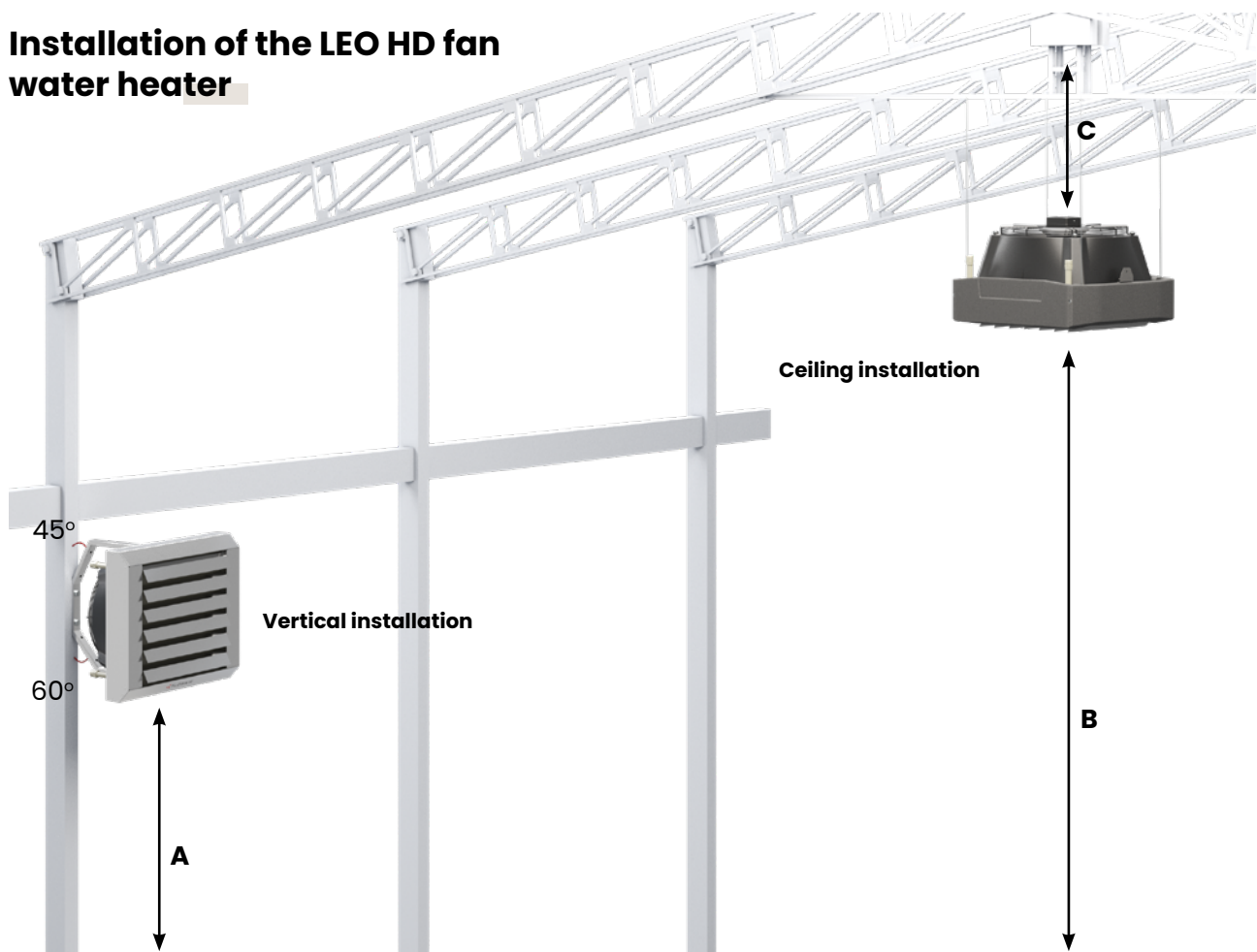

Installation distances

	LEO HD S	LEO HD L
A	min. 2.5 m	min. 2.5 m
B	min. 2.5 m	min. 2.5 m
C	min. 0.3 m	min. 0.3 m

Installation accessories

Rotary console (AISI316L)

Allows easy installation at different angles to vertical and horizontal positions.



Ceiling brackets (AISI316L)

Designed for ceiling installation (optional equipment). Easy ceiling installation on pins.



⁰¹ With vertical arrangement of the air blades. For ceiling installation, the installation height should be selected according to the non-isothermal vertical range.

Control and control elements

TS controller – basic version

This is the simplest 3-speed fan control system. The operation of the fan heater is regulated by a 3-speed controller with thermostat.



HMI controller – basic version

This is an advanced 3-speed fan control system with an HMI programmable controller.



T-box controller – BMS version

This is intelligent control tailored to individual needs thanks to the T-box controller with touchscreen display.



TRA+ R55 for IP 66

It's a simple unit setting. TRA provides 5-speed fan speed control, while R55 is an ON/OFF thermostat adapted to a higher IP protection level.



	R55 + TRA	TS controller	HMI controller	T-box controller
Types of regulation/control:				
Manual 3-step air flow regulation		✓	✓	✓
Automatic 3-step air flow regulation			✓	✓
Manual 5-step air flow regulation	✓			
Modes				
Heating / Cooling / Ventilation	✓	✓	✓	✓
Operation in continuous or thermostatic mode	✓	✓	✓	✓
Weekly programmer			✓	✓
BMS			✓	✓
Antifreeze			✓	✓
Integration with FLOWAIR SYSTEM				✓
Weekly programmer for each zone				✓ ⁽¹⁾
Individual settings for each zone				✓ ⁽¹⁾
Individual description of the controlled zone				✓ ⁽¹⁾
Antifreeze for each zone				✓ ⁽¹⁾
IP / Insulation class	55	20	20	20
Max. number of connected units				
Via controller	1	7	5	31
Via additional splitters	n/a	36	36	n/a

⁽¹⁾ T-box Zone



Control elements

Wall-mounted temperature sensor

Wall mounted temperature sensor makes it possible to measure the temperature in a different zone than the controller.



Possibility of temperature measurement

Controller	Temperature sensor	The connection of wall mounted temperature sensor
TS	integrated	n/a
HMI	NTC or integrated	to HMI controller
T-box	PT-1000 or integrated	to DRV control module

RX splitters

Splitter of control signal for connection of several LEO HD units with 3-step fans (AC IP54) to a one controller. It is possible to combine max. 3 splitters RX, so that the single controller can control up to 36 units simultaneously.



Max. number of controlled units via single controller

Splitter	LEO HD S AC IP54	LEO HD L AC IP54
1 pcs. RX	12	6
2 pcs. RX	24	12
3 pcs. RX	36	18

Connection diagrams

TS / HMI controller

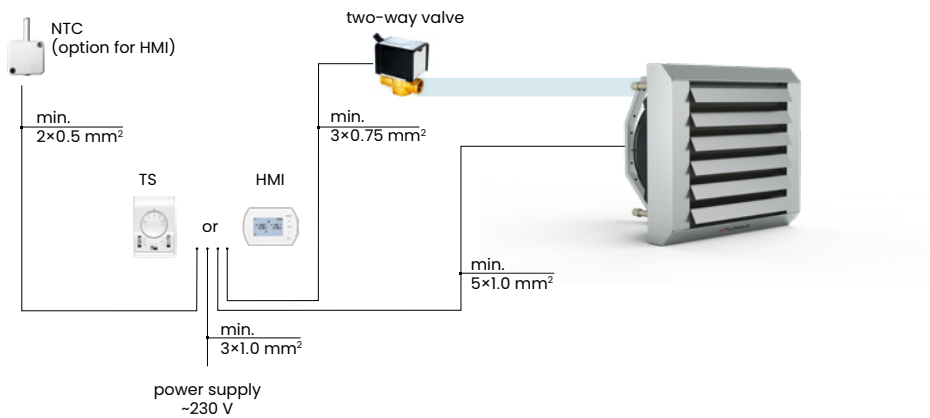

T-box controller

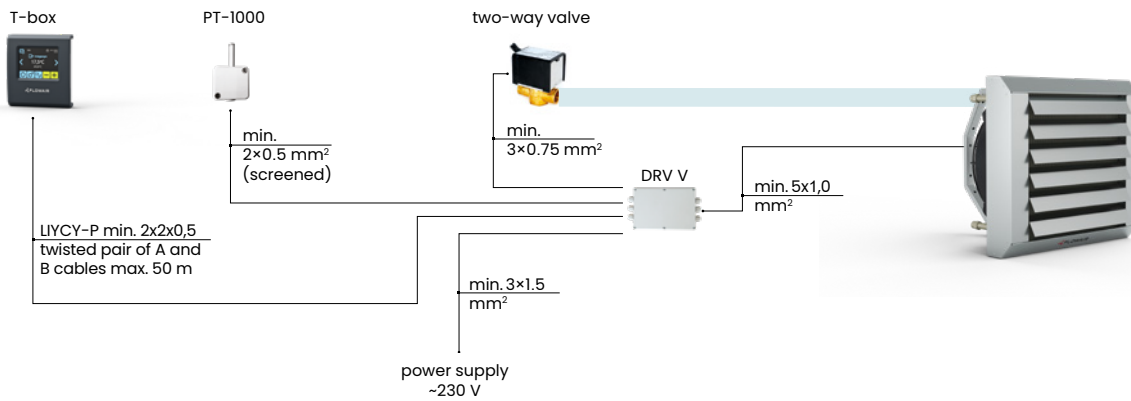

TRA R55 controller

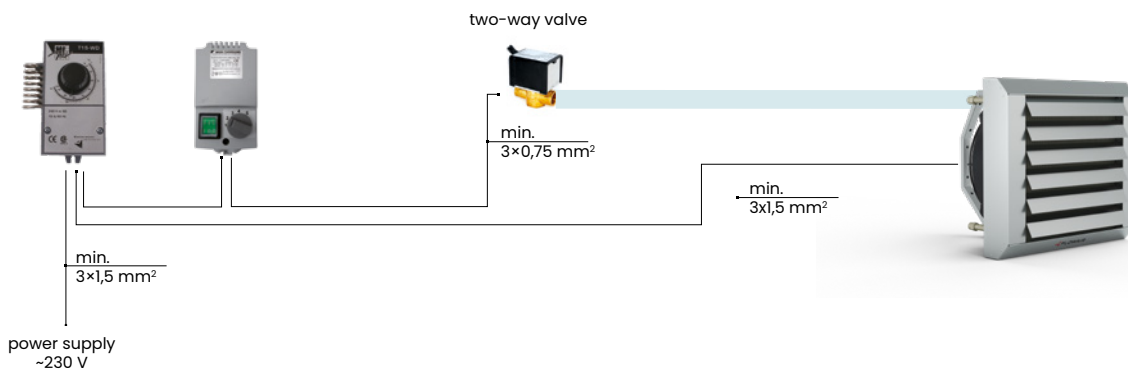



Accessories LEO HD

Mixing chamber

Mixing chambers (KM) allow fresh air to be supplied to the room. LEO HD + KM + UVO is the easiest way to create the efficient ventilation in a objects, at the lowest possible energy consumption, without additional systems. The mixing chamber/heater combo is easy to assemble thanks to the matching brackets.



Dimensions

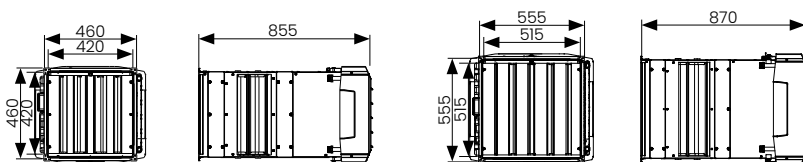

LEO HD S AC IP54 + KM S

LEO HD L AC IP54 + KM L
LEO HD L AC IP66 + KM L

Mixing chamber installation

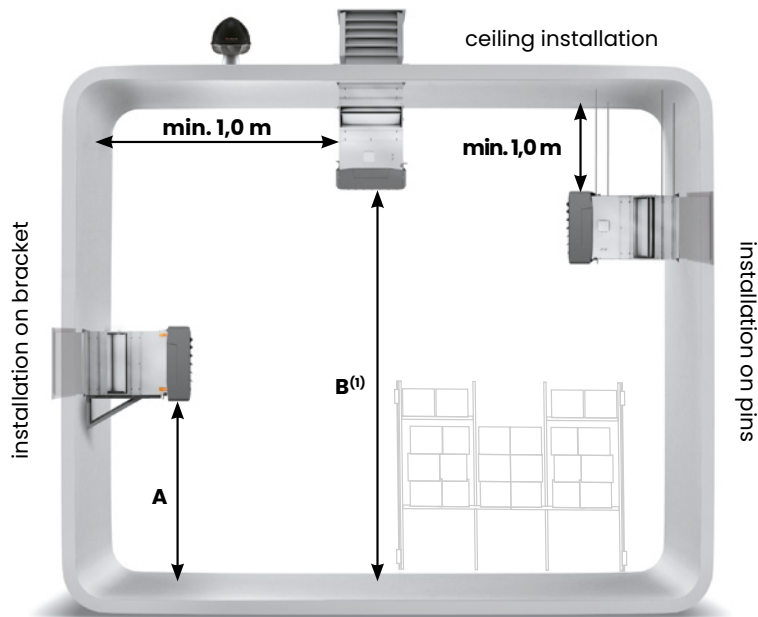

LEO HD + KM + UVO is the easiest way to the efficient ventilation in a room without the need for additional systems.



The mounting bracket allows the unit to be easily and aesthetically mounted to vertical partitions.

(1) With vertical arrangement of the air blades. For ceiling installation, the installation height should be selected according to the non-isothermal vertical range.

Installation distances

	LEO HD S AC IP54 + KM S	LEO HD L AC IP54 + KM L LEO HD L AC IP66 + KM L
A	max. 3,0	2,5 – 5,0
B	2,5 – 4,0	2,5 – 6,0

Technical data

	LEO HD S AC IP54 + KM S	LEO HD L AC IP54 + KM L LEO HD L AC IP66 + KM L
Max. air flow stream ⁽¹⁾ [m ³ /h]	1100	2400
Nominal heating power (70/50/16°C, III biegi) [kW]	7,2	14,4
Power supply [V/Hz]	230/50	230/50
Max. Current consumption [A]	0,6	1,5
Max. Power consumption [W]	130	340
IP / Insulation class	54/F	54/F
Max. Acoustic pressure level ⁽²⁾ [dB(A)]	56,3	64,1
Max. Acoustic power level ⁽³⁾ [dB(A)]	71,4	79,2
Horizontal range ⁽⁴⁾ [m]	7,5	13,5
Vertical range ⁽⁵⁾ [m]	3,2	5,0
Max. heating water temperature [°C]	120	120
Max. operating pressure [MPa]	1,6	1,6
Connection	1/2"	3/4"
Weight of unit [kg]	26,8	35,5
Weight of unit filled with water [kg]	28,0	37,5

⁽¹⁾ Capacity with air intake and 100% fresh air – air flow measured in accordance with ISO 5801

⁽²⁾ Acoustic pressure level for a room with average sound absorption, volume 1500 m³, at a distance of 5m from the unit

⁽³⁾ In accordance with EN ISO3744

⁽⁴⁾ Horizontal range of the isothermal air stream, at a speed limit of 0.5 m/s

⁽⁵⁾ Vertical range of non-isothermal air stream at T = 5°C, at a speed limit of 0.5 m/s

SYSTEM FLOWAIR



The SYSTEM FLOWAIR is a complete range of heating and ventilation units integrated by a single controller. The T-box Zone controller allows up to 31 units from our range to work together in 31 independent zones.

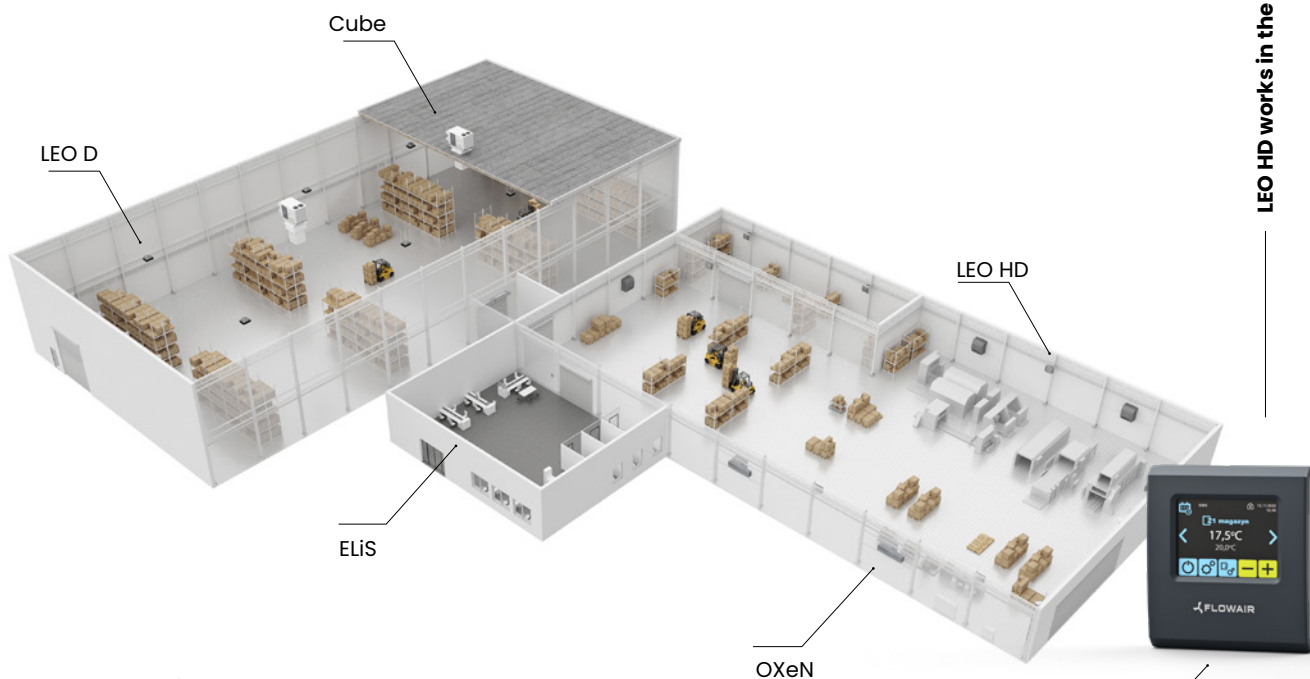

LEO HD works in the SYSTEM

- LEO HD - water fan heaters
- LEO D - destratificator
- ELiS and Slim - Air curtains
- OXeN - Ventilation unit with heat recovery
- Cube - Rooftop devices

T-box Zone



Control of devices with one controller



Local regulation of devices



Advanced control of ventilating and heating devices



Control the devices according to your time schedule and individual needs



Antifreeze protects the devices against low temperatures

Integration and interoperability of devices

The T-box Zone intelligent touch controller has a number of functions necessary to effectively manage the operation of the heating and ventilation system that until now were restricted to extensive Building Management Systems (BMSs).

The SYSTEM enables devices to work together to ensure a higher thermal comfort and energy efficiency. The combined operation of heaters and destratifiers makes it possible to effectively utilize heat from the upper parts of the room, while saving the heat energy supplied by the heaters.

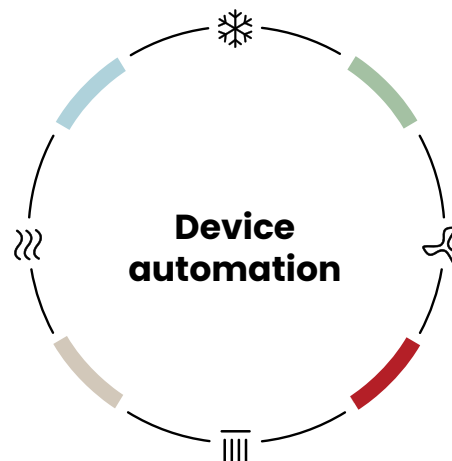

Interoperability with heat pumps

The LEO HD fan heater can be supplied with low-temperature heating medium (60–40°C). Units can provide cooperation with heat pumps.

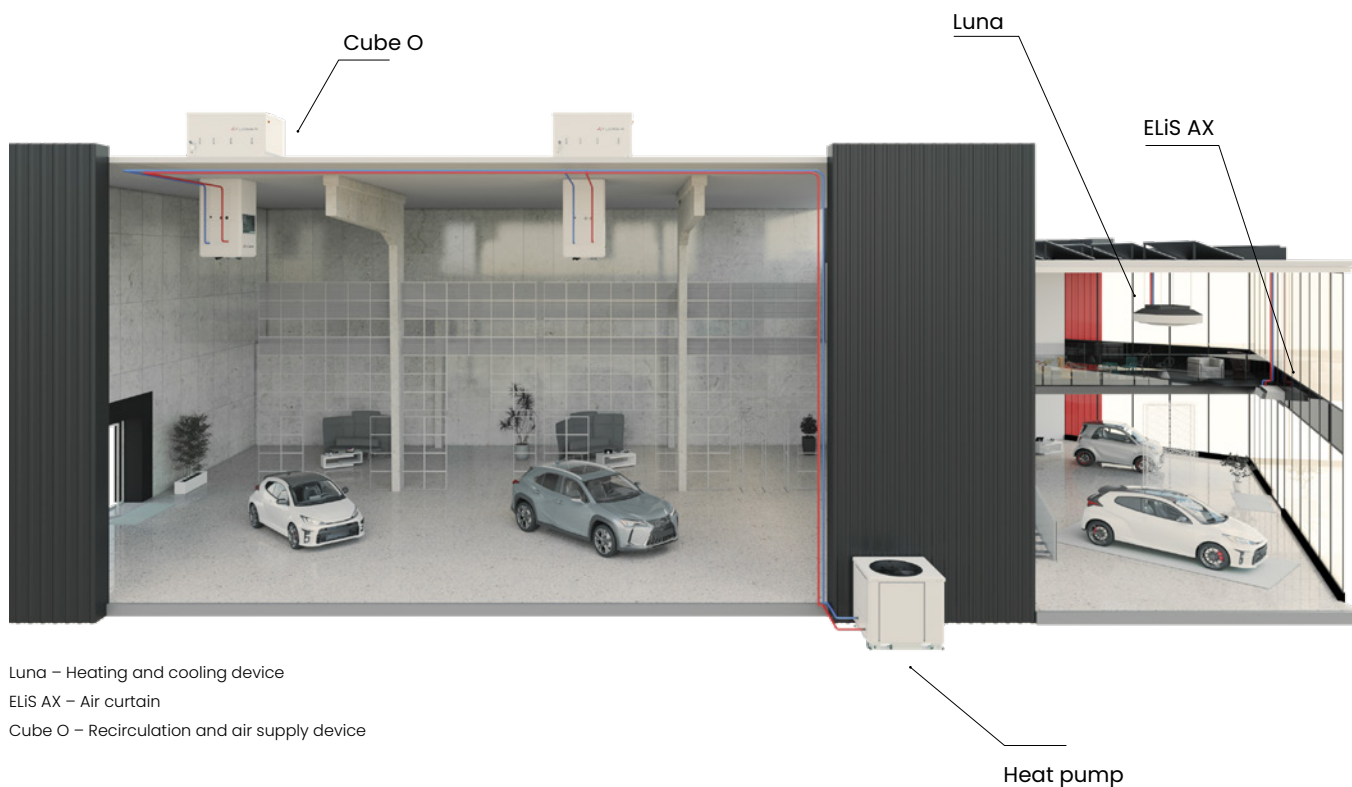

Heating capacities

LEO HD

Tw1/Tw2 = 45/35°C					Tw1/Tw2 = 70/50°C					Tw1/Tw2 = 55/45°C				
Tp1	PT	Qw	Δpw	Tp2	Tp1	PT	Qw	Δpw	Tp2	Tp1	PT	Qw	Δpw	Tp2
[°C]	[kW]	[l/h]	[kPa]	[°C]	[°C]	[kW]	[l/h]	[kPa]	[°C]	[°C]	[kW]	[l/h]	[kPa]	[°C]
LEO HD S EC														
V = 1650 m³/h 54,0 db(A)⁽⁰⁾														
10,0	6,3	550	6,9	21,5	10,0	10,4	454	4,5	29	10,0	8,7	760	11,9	26
15,0	5,1	446	4,8	24	15,0	9,2	403	3,7	32	15,0	7,6	660	9,2	29
20,0	3,9	339	3	27	20,0	8,1	352	2,9	35	20,0	6,4	558	6,8	32
V = 1300 m³/h 46,8 db(A)⁽⁰⁾														
10,0	5,5	477	5,4	22,5	10,0	9,2	401	3,6	31	10,0	7,7	671	9,5	27,5
15,0	4,5	386	3,7	25	15,0	8,2	357	3	33,5	15,0	6,7	582	7,4	30
20,0	3,4	294	2,3	27,5	20,0	7,1	311	2,3	36	20,0	5,7	493	5,5	33
V = 950 m³/h 40,7 db(A)⁽⁰⁾														
10,0	4,5	392	3,8	24	10,0	7,6	330	2,6	33,5	10,0	6,3	552	6,7	29,5
15,0	3,7	317	2,6	26,5	15,0	6,7	293	2,1	36	15,0	5,5	479	5,2	32
20,0	2,8	241	1,6	28,5	20,0	5,9	256	1,7	38	20,0	4,7	405	3,9	34,5
V = 600 m³/h 32,1 db(A)⁽⁰⁾														
10,0	3,3	289	2,2	26,5	10,0	5,6	244	1,5	37,5	10,0	4,7	407	3,9	33
15,0	2,7	234	1,5	28	15,0	5	217	1,2	39	15,0	4,1	354	3	36,5
20,0	2	176	0,9	30	20,0	4,3	189	1	41	20,0	3,5	299	2,3	36,5
LEO HD S AC														
V = 2000 m³/h 54,4 db(A)⁽⁰⁾														
10,0	7,1	615	8,5	20,5	10,0	11,8	517	5,7	27,5	10,0	9,9	867	15	24,5
15,0	5,7	499	5,8	23,5	15,0	10,5	459	4,6	30,5	15,0	8,6	752	11,6	27,5
20,0	4,4	380	3,6	26,5	20,0	9,2	401	3,6	33,5	20,0	7,3	636	8,6	30,5
V = 1600 m³/h 48,8 db(A)⁽⁰⁾														
10,0	6,2	540	6,7	21,5	10,0	10,4	454	4,5	29	10,0	8,7	760	11,9	26
15,0	5	437	4,6	24,5	15,0	9,2	403	3,7	32	15,0	7,6	660	9,2	29
20,0	3,8	333	2,9	27	20,0	8,1	352	2,9	35	20,0	6,4	558	6,8	32
V = 1250 m³/h 42,0 db(A)⁽⁰⁾														
10,0	5,4	465	5,2	22,5	10,0	9	392	3,5	31	10,0	7,5	655	9,1	28
15,0	4,3	377	3,6	25,5	15,0	8	348	2,8	34	15,0	6,5	569	7	30,5
20,0	3,3	287	2,2	28	20,0	7	304	2,2	36,5	20,0	5,5	481	5,2	33
LEO HD L EC														
V = 3000 m³/h 56,0 db(A)⁽⁰⁾														
10,0	12,2	1063	5,2	22	10,0	20,5	895	3,5	30	10,0	17,4	1517	9,5	27
15,0	9,8	854	3,5	24,5	15,0	18,1	792	2,8	33	15,0	15	1311	7,3	30
20,0	7,4	641	2,1	27,5	20,0	15,7	688	2,2	35,5	20,0	12,7	1103	5,3	32,5
V = 2750 m³/h 53,1 db(A)⁽⁰⁾														
10,0	11,6	1009	4,7	22,5	10,0	19,4	849	3,2	31	10,0	16,5	1439	8,6	28
15,0	9,3	810	3,2	25	15,0	17,2	752	2,6	33,5	15,0	14,3	1244	6,6	30,5
20,0	7	608	1,9	27,5	20,0	14,9	653	2	36	20,0	12	1047	4,9	33

Tw1/Tw2 = 45/35°C					Tw1/Tw2 = 70/50°C					Tw1/Tw2 = 55/45°C				
Tp1	PT	Qw	Δpw	Tp2	Tp1	PT	Qw	Δpw	Tp2	Tp1	PT	Qw	Δpw	Tp2
[°C]	[kW]	[l/h]	[kPa]	[°C]	[°C]	[kW]	[l/h]	[kPa]	[°C]	[°C]	[kW]	[l/h]	[kPa]	[°C]
V = 1850 m³/h 45,7 db(A)⁽¹⁾														
10,0	9	785	3	24,5	10,0	15,1	662	2,1	34	10,0	12,8	1119	5,5	30,5
15,0	7,3	630	2,1	26,5	15,0	13,4	586	1,7	36,5	15,0	11,1	968	4,2	32,5
20,0	5,4	470	1,2	28,5	20,0	11,6	509	1,3	38,5	20,0	9,4	815	3,1	35
V = 950 m³/h 36,2 db(A)⁽¹⁾														
10,0	5,7	495	1,3	28	10,0	9,6	419	0,9	40	10,0	8,1	708	2,4	35,5
15,0	4,6	395	0,9	29	15,0	8,5	371	0,7	41	15,0	7	612	1,9	36,5
20,0	3,3	289	0,5	30,5	20,0	7,3	321	0,6	42,5	20,0	5,9	516	1,4	38
LEO HD L AC														
V = 3800 m³/h 40,2 db(A)⁽¹⁾														
10,0	14,1	1224	6,7	21	10,0	23,5	1030	4,5	28,5	10,0	20	1747	12,2	25,5
15,0	11,3	983	4,5	24	15,0	20,8	911	3,6	31	15,0	17,3	1509	9,4	28,5
20,0	8,5	738	2,7	26,5	20,0	18,1	791	2,8	34	20,0	14,6	1270	6,9	31,5
V = 2400 m³/h 52,6 db(A)⁽¹⁾														
10,0	10,7	927	4,1	23	10,0	17,9	781	2,8	32	10,0	15,2	1322	7,4	28,5
15,0	8,6	745	2,8	25,5	15,0	15,8	691	2,2	34,5	15,0	13,1	1143	5,7	31
20,0	6,4	558	1,7	28	20,0	13,7	600	1,7	36,5	20,0	11	963	4,2	33,5
V = 1400 m³/h 40,2 db(A)⁽¹⁾														
10,0	7,5	651	2,2	26	10,0	12,6	550	1,5	36,5	10,0	10,7	929	3,9	32,5
15,0	6	522	1,5	27,5	15,0	11,1	487	1,2	38,5	15,0	9,2	804	3	34,5
20,0	4,5	388	0,9	29,5	20,0	9,7	422	0,9	40	20,0	7,8	677	2,2	36
LEO HD L AC IP66														
V = 3800 m³/h 62,3 db(A)⁽¹⁾														
10,0	14,1	1224	6,7	21	10,0	23,5	1030	4,5	28,5	10,0	20	1747	12,2	25,5
15,0	11,3	983	4,5	24	15,0	20,8	911	3,6	31	15,0	17,3	1509	9,4	28,5
20,0	8,5	738	2,7	26,5	20,0	18,1	791	2,8	34	20,0	14,6	1270	6,9	31,5
V = 3500 m³/h 61,3 db(A)⁽¹⁾														
10,0	13,4	1166	6,1	21,5	10,0	22,4	981	4,2	29	10,0	19,1	1664	11,2	26
15,0	10,8	937	4,2	24	15,0	19,8	868	3,3	31,5	15,0	16,5	1438	8,6	29
20,0	8,1	703	2,5	27	20,0	17,2	753	2,6	34,5	20,0	13,9	1210	6,3	31,5
V = 2930 m³/h 57,5 db(A)⁽¹⁾														
10,0	12,1	1049	5,1	22	10,0	20,2	883	3,5	30,5	10,0	17,2	1496	9,2	27,5
15,0	9,7	842	3,4	25	15,0	17,9	781	2,8	33	15,0	14,8	1293	7,1	30
20,0	7,3	632	2,1	27,5	20,0	15,5	678	2,2	35,5	20,0	12,5	1088	5,2	32,5
V = 2300 m³/h 52,3 db(A)⁽¹⁾														
10,0	10,4	902	3,9	23,5	10,0	17,4	761	2,6	32,5	10,0	14,8	1287	7	29
15,0	8,4	725	2,6	25,5	15,0	15,4	673	2,1	34,5	15,0	12,8	1113	5,4	31,5
20,0	6,3	543	1,6	28	20,0	13,4	84	1,7	37	20,0	10,8	937	4	33,5
V = 1400 m³/h 40,2 db(A)⁽¹⁾														
10,0	7,5	651	2,2	26	10,0	12,6	550	1,5	36,5	10,0	10,7	929	3,9	32,5
15,0	6	522	1,5	27,5	15,0	11,1	487	1,2	38,5	15,0	9,2	804	3	34,5
20,0	4,5	388	0,9	29,5	20,0	9,7	422	0,9	40	20,0	7,8	677	2,2	36

V – air flow

PT – heating capacity

Tp1 – inlet air temperature

Tp2 – outlet air temperature

Tw1 – inlet water temperature

Tw2 – outlet water temperature

Qw – water flow rate in heat exchanger

Δpw – water pressure drop in heat exchanger

(1) – acoustic pressure level for a room with average sound absorption, volume

3000m³, at a distance of 5m from the unit



FLEXIHEAT UK LTD

www.flexiheatuk.com

01202 822221